



## **TL SERIES**

### **USER MANUAL**

**TL-1201  
TL-1501  
TL-1561  
TL-1500  
TL-1550  
TL-1800**

**Turbosound Ltd.  
Star Road, Partridge Green  
West Sussex RH13 8RY England  
Tel: +44 (0)1403 711447 Fax: +44 (0)1403 710155  
web: [www.turbosound.com](http://www.turbosound.com)**

**Issue 1.0 Copyright © 2001 Turbosound Ltd.**

**Contents**

Introduction .....	3
Thanks .....	3
Unpacking the TL series loudspeaker .....	3
Features .....	4
Product Range Summary.....	5
TL-1201 .....	5
TL-1501 .....	5
TL-1561 .....	6
TL-1500 .....	6
TL-1550 .....	7
TL-1800 .....	7
System requirements.....	8
Amplifier considerations.....	9
Equalisation .....	9
Dispersion .....	9
Mounting and Fixing .....	11
Rigging hardware .....	11
Choosing the best location .....	12
Maintenance .....	13
Removal of the low frequency driver(s).....	13
Removal of the mid frequency driver.....	13
Removal of the high frequency compression driver .....	13
Appendix A .....	14
Use of thread locking compounds.....	14
Appendix B .....	15
Spares and Accessories .....	15
Flying Accessories .....	15
Appendix C .....	16
Technical Specifications.....	16
Appendix D .....	18
Limited Warranty .....	18

## **INTRODUCTION**

### **Thanks**

Thank you for choosing a TURBOSOUND TL series loudspeaker product for your application. Please spare a little time to digest the contents of this manual, so that you can obtain the best possible performance from this unit.

All TURBOSOUND products are carefully engineered for world class performance and reliability.

If you would like further information about this or any other TURBOSOUND product, please contact us. Detailed product information is available on our web site at [www.turbosound.com](http://www.turbosound.com)

We look forward to helping you in the near future.

Congratulations, you have just purchased a professional loudspeaker system from the renowned Turbosound range, designed to give you the best in audio quality and many years of reliable, trouble free operation. It offers superior audio quality, full technical documentation, and rigging and flying hardware options. Please read through this manual carefully before you attempt to operate the loudspeaker system. It contains valuable information enabling you to quickly and easily set up and connect the loudspeakers, important system and set-up checks together with positioning and mounting instructions.

### **Unpacking the TL series loudspeaker**

After unpacking the unit please check carefully for damage. If damage is found, please notify the carrier concerned at once. You, the consignee, must instigate any claim. Please retain all packaging in case of future re-shipment.

## FEATURES

- **Superb audio quality:** carefully designed and matched loudspeaker drive units are used to give you exceptional performance and many years of reliable, trouble free operation.
- **High quality loudspeaker components** are used throughout the range. Low frequency drivers are specified for high sensitivity and durability, while high frequency drivers are selected for consistent and reliable performance.
- **High frequency protection system:** two-stage thermal overload circuits on all two way products prevents damage to the HF drive units from both transient peaks and long term heating effects.
- **Professional appearance:** TL series enclosures are equally suited to live sound as well as permanently installed applications.
- **Easy transportability:** comfortable, ergonomic flush handles are provided on all TL series enclosures for easy lifting and transportation in mobile sound reinforcement applications.
- **Wide dispersion:** TL series enclosures are designed to give wide and even dispersion patterns in order to maximise sound coverage over a given area from single loudspeakers.
- **Solid construction:** all Turbosound TL series cabinets are built from high grade birch plywood and are finished in a durable semi-matt textured paint.
- **Integral rigging points:** fitted as standard, enabling use with optional M10 shoulder eyebolts for many types of fixed installations. All models are type-tested for load rating to ensure safe rigging.
- **Pole mount and tripod stand use** is facilitated by the provision of integral pole mount fittings on all models with the exception of the TL-1561.
- **Speakon NL4MP connectors** are fitted to all TL series enclosures, enabling simple and easy hook-ups as well providing loop-in / loop-out facilities to additional enclosures.

## PRODUCT RANGE SUMMARY

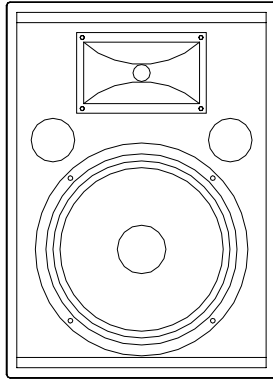

### TL-1201

The TL-1201 is a compact trapezoidal passive two-way loudspeaker enclosure designed for use in a wide variety of live sound applications as well as in fixed installations ranging from cafes, pubs, bars and restaurants to retail stores and houses of worship.

It consists of a 12" reflex-loaded low frequency driver and a 1" high frequency compression driver in an optimally tuned, birch plywood enclosure. These high-grade components are matched with an internal second order passive crossover network.

Its wide dispersion pattern of 70°H x 40°V enables a variety of foreground sound applications, including use as a delay speaker in distributed sound reinforcement system.

Two Neutrik Speakon NL4MP connectors provide input and loop in / loop out connections to the enclosure. Internal threaded rigging points provided on the top and back are designed for use with optional M10 shoulder eyebolts for rigging single enclosures in fixed installations. An integral 35mm pole mount is fitted for use with standard tripods and poles.

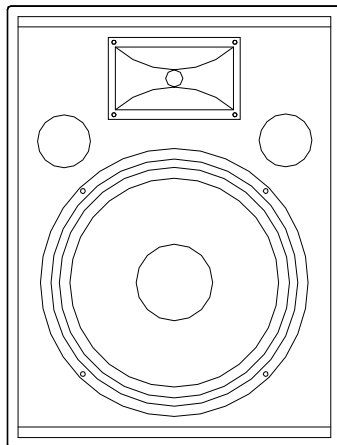

### TL-1501

The TL-1501 is a trapezoidal passive two-way loudspeaker enclosure designed for use in a wide variety of live sound applications as well as in fixed installations ranging from cafes, pubs, bars and restaurants to retail stores and houses of worship.

It consists of a 15" low frequency driver and a 1" high frequency compression driver in an optimally tuned, birch plywood enclosure. These high-grade components are matched with an internal second order passive crossover network. The TL-1501 is designed to provide wide horizontal coverage (70°H x 40°V) making it suitable for use in a variety of

foreground sound applications, including use as a delay speaker in distributed sound reinforcement system.

Two Neutrik Speakon NL4MP connectors provide input and loop in / loop out connections to the enclosure. Internal fixing points provided on the top and back can be used with optional M10 shoulder eyebolts for rigging single enclosures in fixed installations. An integral 35mm pole mount is fitted for use with standard tripods and poles.

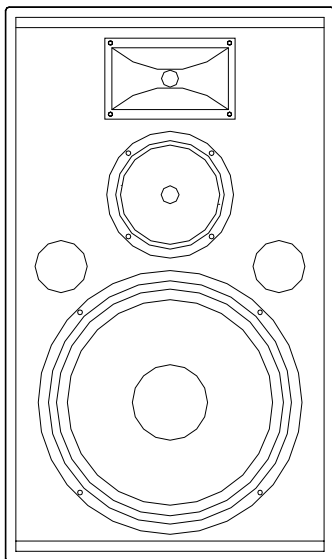

#### **TL-1561**

The TL-1561 is a trapezoidal passive three-way loudspeaker enclosure designed for use in a wide variety of live sound applications as well as in fixed installations ranging from cafes, pubs, bars and restaurants to retail stores and houses of worship.

It consists of a front-loaded 15" low frequency driver, a front-loaded 6.5" mid frequency driver and a 1" high frequency compression driver on a 70°H x 40°V high frequency horn, matched with an internal second order passive crossover network.

The three-way design affords an increase in mid-range energy when compared to its two-way counterpart, as well as providing extended low frequency response due to the increased enclosure size.

A rear panel connector plate carries two Neutrik Speakon NL4MP connectors for loop in / loop out connections to additional enclosures. Flush handles are provided for easy lifting and carrying.

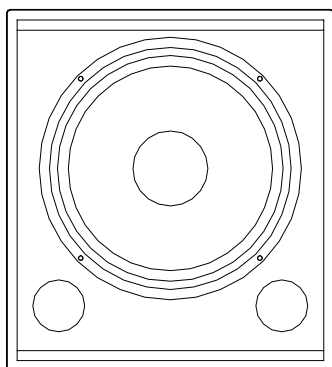

#### **TL-1500**

The TL-1500 is a trapezoidal 15" low frequency enclosure designed to give low frequency support to TL-1201 or TL-1501 enclosures. As such it can be used in a wide variety of live sound applications as well as in fixed installations ranging from cafes, pubs, bars and restaurants to retail stores and houses of worship.

It consists of a front-loaded 15" low frequency driver and an internal high pass crossover network in an optimally tuned, birch plywood enclosure. The cabinet is fitted with a pole mount socket in the top panel.

Two Neutrik Speakon NL4MP connectors provide input and high pass output connections to TL-1201 or TL-1501 enclosures. Flush handles are provided for easy lifting and carrying.

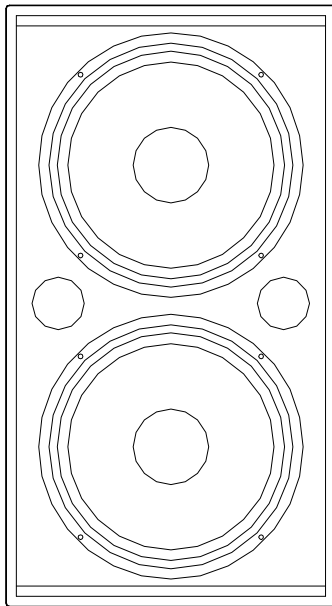

### **TL-1550**

The TL-1550 is a trapezoidal dual 15" low frequency enclosure designed to give low frequency support to TL-1201 or TL-1501 enclosures. As such it can be used in a wide variety of live sound applications as well as in fixed installations ranging from cafes, pubs, bars and restaurants to retail stores and houses of worship.

It consists of two front-loaded 15" low frequency drivers and an internal high pass crossover network in an optimally tuned, birch plywood enclosure. The cabinet is fitted with a pole mount socket in the top panel.

Two Neutrik Speakon NL4MP connectors provide input and high pass output connections to TL-1201 or TL-1501 enclosures. Flush handles are provided for easy lifting and carrying.

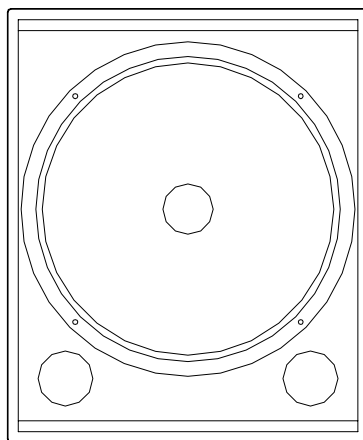

### **TL-1800**

The TL-1800 is a trapezoidal 18" low frequency enclosure designed to give low frequency support to TL-1201 or TL-1501 enclosures. As such it can be used in a wide variety of live sound applications as well as in fixed installations ranging from cafes, pubs, bars and restaurants to retail stores and houses of worship.

It consists of a front-loaded 18" low frequency driver and an internal high pass crossover network in an optimally tuned, birch plywood enclosure. The cabinet is fitted with a pole mount socket in the top panel.

Two Neutrik Speakon NL4MP connectors provide input and high pass output connections to TL-1201 or TL-1501 enclosures. Flush handles are provided for easy lifting and carrying.

**SYSTEM REQUIREMENTS**

TL series enclosures are passive loudspeaker systems. This means that they require only one amplifier channel for correct operation, the frequency splitting between the low frequency driver and the high frequency driver or mid and high frequency driver in two-way and three-way products being accomplished by the internal passive crossover network built into each enclosure.

If additional low frequency enclosures are used in conjunction with TL series two-way enclosures to extend low frequency response, no additional amplifier channels or external electronic crossovers are required. All TL series low frequency enclosures are equipped with internal high pass crossover networks, splitting the full range signal and feeding the appropriate frequency band to the two-way enclosure. Therefore a full range system consisting of, for example, a TL-1201 and a TL-1500 can be powered from a single amplifier as shown below, thereby saving the expense of additional amplifiers and external crossovers.

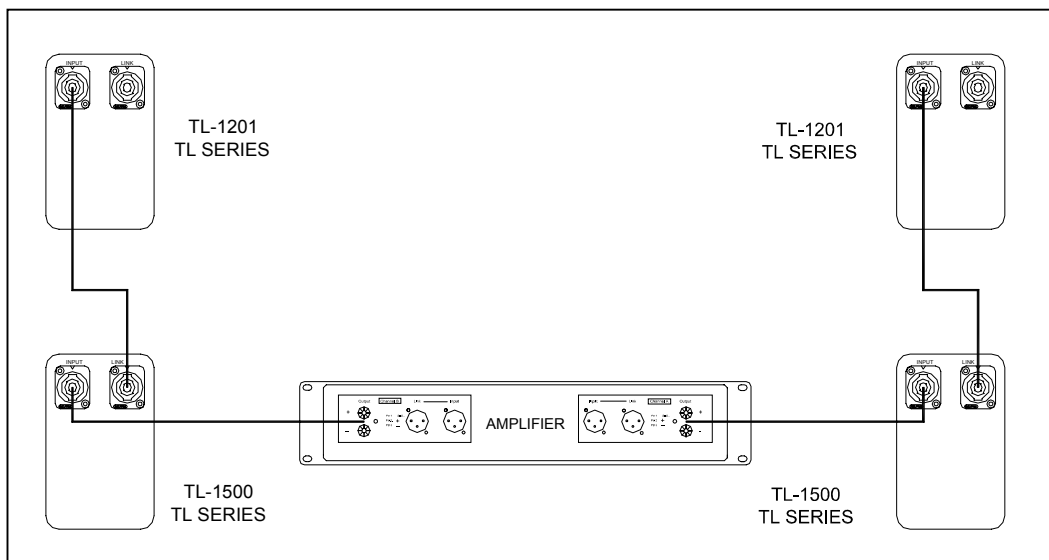

1. Connect the amplifier output to the Speakon INPUT socket on the bass enclosure.
2. Then connect an additional speaker cable from the LINK socket on the bass cabinet to the INPUT socket on the full range cabinet. Speakon pin connections are shown below.

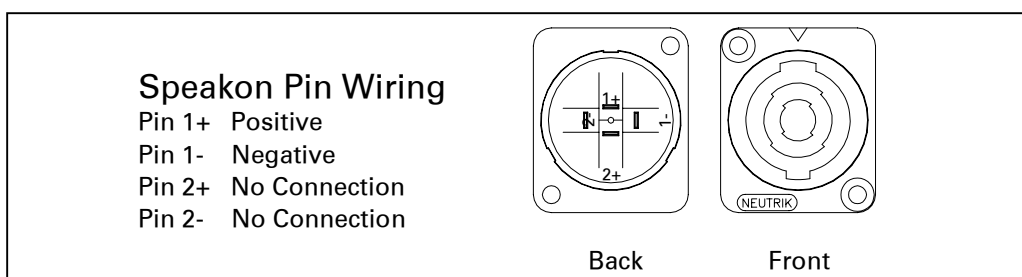



### **Amplifier considerations**

Turbosound speaker enclosures should be driven by high quality power amplifiers designed for true professional use. Such amplifiers will have balanced inputs, DC and RF fault protection, and well-designed cooling systems for reliability. Turbosound power amplifiers such as the TMC-T1000 are available and recommended for this purpose.

The program power listed in the loudspeaker's technical specification is the best guide to the size of amplifier required for general-purpose applications. The amplifier should therefore be capable of delivering long term broadband power equal to the loudspeaker's program power rating at the loudspeaker's stated nominal impedance. This approach allows sufficient headroom to generate good dynamic range.

**RECOMMENDED AMPLIFIER POWER RATINGS:**

The amplifier's rated r.m.s. continuous power output (20Hz – 20kHz, per channel) should be equal to the program power handling of the loudspeaker at its nominal impedance.

In general, the more powerful the amplifier the better it will sound, provided that it is not driven into sustained clipping. It should be understood that overdriving an insufficiently powered amplifier is more likely to cause loudspeaker damage – the total energy in a heavily clipped signal is far higher than in an unclipped signal – than operating a more powerful amplifier within its ratings.

### **Equalisation**

TL series enclosures are designed to provide smooth and even frequency response. They do not need excessive amounts of external equalisation to overcome the sonic deficiencies often found in many lesser designs.

In order to compensate for the room acoustics, TL series enclosures require only minimal equalisation. As in any system, over-equalisation introduces phase shifts, distortion and a reduction in headroom, usually causing more problems than it cures. Under most circumstances a 1/3 or 1/2 octave graphic equaliser will generally be adequate, with the fader settings applied smoothly and as little as possible for the required room compensation. Most rooms will have resonances that will be excited at particular frequencies needing some *cut* to help tame the sound. These problems are most pronounced at the lower frequencies where loudspeakers generally exhibit very little directional control. If you find that the system needs a lot of *boost* at lower frequencies you may need additional sub-bass units. It is good practice to use as little equalisation as possible, aiming to cut frequencies rather than adding large amounts of boost.

### Dispersion

TL series enclosures are designed to provide relatively wide ( $70^\circ$ ) horizontal coverage. This allows the majority of live sound applications to be covered with enclosures placed individually to take advantage of this performance feature, for example either side of a stage in a pub or small club environment as shown below. The loudspeakers should be either mounted on tripod stands or supported on straight poles on top of TL-1500, TL-1550 or TL-1800 bass enclosures. In order to optimise the sound coverage, point the loudspeakers inwards slightly, such that the centre lines intersect at a distance approximately equal to twice the width of the stage.

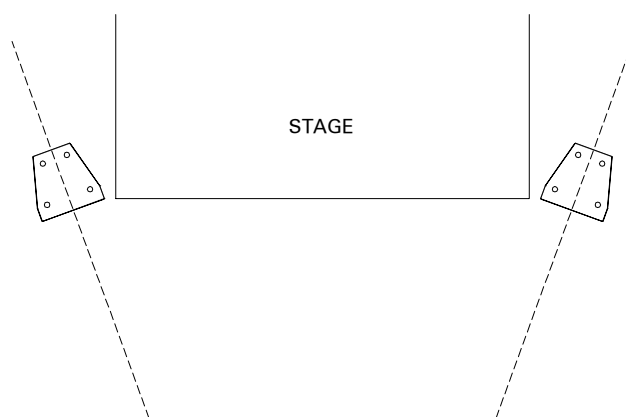

It is possible to array TL series loudspeakers in order to achieve wider horizontal coverage and in these applications it is recommended that the cabinets be placed such that the trapezoidal sides are touching to ensure that the appropriate splay angle is observed. For guidance when designing a sound system, a  $70^\circ$  horizontal polar pattern equals an angle of  $35^\circ$  either side of the centre line at which the sound pressure level is 6dB down with respect to centre, (averaged over the whole frequency range of the loudspeaker). Thus a  $40^\circ$  vertical dispersion gives an angle of  $20^\circ$  above and below the horizon.

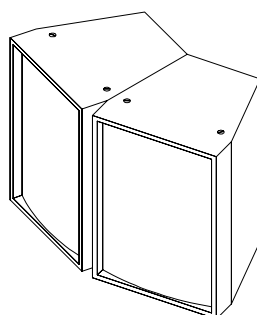

## MOUNTING AND FIXING

### Rigging hardware

A versatile range of mounting hardware is available that allows enclosures to be used in a variety of ways, in either mobile sound reinforcement applications or permanent installations.

A **pole mount / tripod stand fitting** is fitted to the bottom of the TL-1201 and TL-1501 full range cabinets. Use this pole mount facility with either optional Turbosound PA-100 35mm diameter poles, or conventional loudspeaker tripod stands. Doing so will raise the TL-1201 or TL-1501 loudspeaker above the heads of an audience, providing better sound coverage from a single enclosure. A matching pole mount socket is provided on the top of the TL-1500, TL-1550 and TL-1800 low frequency enclosures to accept the PA-100 pole.

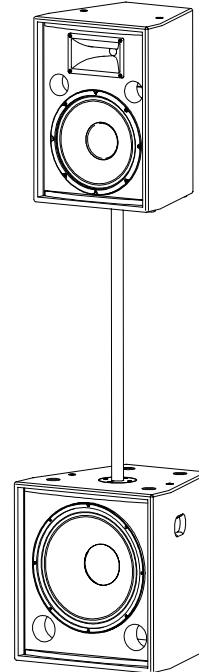

All TL series cabinets, including low frequency enclosures, can be rigged in permanent installations using **optional M10 shoulder eyebolts**. The top of the cabinet is provided with two internal threaded rigging points, and a further rigging point is provided on the back panel, below the connector plate, used to determine the amount of downward angle. As supplied, these rigging points are fitted externally with M10 countersunk bolts. To facilitate rigging of the enclosure simply remove these M10 bolts and replace them with M10 x 18mm shoulder eyebolts using a suitable thread locking compound to avoid the possibility of loosening (please refer to Appendix C: Use of thread locking compounds at the back of this manual). **Note:** Eyebolts must have a thread length of at least 18mm (3/4").

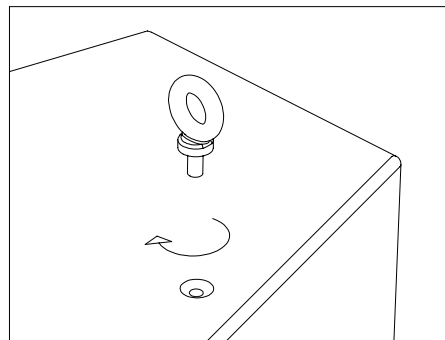
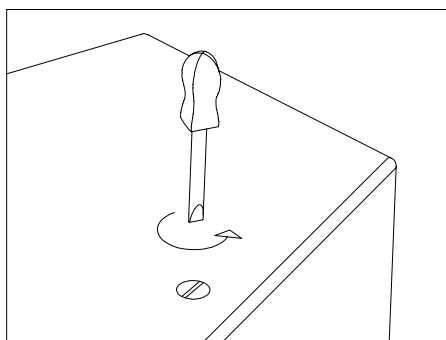

**NOTE:** The rigging points are designed to suspend single enclosures only. There is no facility to hang an additional cabinet below a flown TL series enclosure.

**IMPORTANT:** Any installation, whether temporary or permanent, must be securely attached to the structure of the building using chain, steel wires or web straps which are certified and load rated for the purpose. The combined weight of the sound system, its cables and the rigging system must be safely carried by the points at which attachment is made to the building or structure. Great care must be taken in selecting the attachment points and methods, being absolutely sure of the load carrying capacity of points chosen.

***NOTE:** The rigging of loudspeaker systems is an extremely serious matter with potentially lethal consequences should anything go wrong. It is of vital importance that you, or other people rigging the system, are suitably qualified to do so and have a full understanding of all the factors involved with safety as a number one priority. Turbosound accepts no responsibility for any accident, damage or failure of any rigged system. This rigging information is specifically related to the requirements of TL series enclosures only. For more detailed information on the whole topic of rigging various handbooks are available. If you are in any doubt contact your Turbosound dealer who will be able to refer you to an experienced rigging company.*

### **Choosing the best location**

When using any TL series system, certain room parameters will affect the resultant sound quality and coverage. For example, any boundary like a wall or floor will lift certain frequencies. If you are placing the unit in a corner then a lift at the bass end is to be expected and it may sound rather boomy. This can be compensated for moving the speaker or cutting low frequencies with a graphic equaliser.

When speakers are flown in free space then boundary effects are minimised. The result is a smooth frequency response without any boost at odd frequencies, but the bass end may appear subjectively light. In this case increase the sub-bass level to bring the low end up.

The relationship between sound pressure level and distance is an "inverse square law" so remember that every time the distance from the sound source is doubled the sound level decreases by 6dB. For every 3dB increase of speaker output you need a doubling of input power and you can work out the wattage input needed to give the required SPL levels at various distances from the loudspeaker(s).

## **MAINTENANCE**

If any of the drive units in your TL series cabinet should cease functioning and need a replacement recone or diaphragm, you are advised to remove the faulty unit from the cabinet and send it to a professional service centre authorised to recone and repair Turbosound loudspeakers.

### **Removal of the low frequency driver(s)**

The perforated steel loudspeaker grille is held in place under tension only, fitting into slots at either side of the baffle. There are no screws or other fixings holding the grille in place.

1. Lay the cabinet on its back and, using two small screwdrivers inserted through the mesh of the grille, firmly pull the grille away from the slot at one side of the baffle until it is free. Set the grille aside for later re-assembly.
2. Undo the four screws holding the driver(s) in place and carefully lift it out and away from the cabinet. Make a note of the driver polarity for later reconnection. Disconnect the cables from the drive unit and completely remove the driver from the cabinet.
3. To reinstate the driver(s) simply reverse the above procedure, making sure you observe the correct polarity when reconnecting the cables back into the terminals of the drive units.

### **Removal of the mid frequency driver**

1. Remove the loudspeaker grille as described above and set the grille aside for later re-fitting.
2. Undo the four screws holding the driver(s) in place and carefully lift it out and away from the cabinet. Make a note of the driver polarity for later reconnection. Disconnect the cables from the drive unit and completely remove the driver from the cabinet. To reinstate the driver simply reverse the above procedure, making sure you observe the correct polarity when reconnecting the cables back into the terminals of the drive units.

### **Removal of the high frequency compression driver**

1. Remove the loudspeaker grille as described above and set the grille aside for later re-fitting.
2. Remove the horn/driver assembly by unscrewing the four screws holding the flange in place. Lift it out and away from the cabinet.
3. The high frequency driver can now be disassembled from the HF horn.
4. To reinstate the high frequency horn and compression driver, simply reverse the above procedure making sure you observe the correct polarity when reconnecting the cables back into the terminals of the drive unit.

## APPENDIX A

### Use of thread locking compounds

When assembling flying hardware to TL series loudspeaker enclosures it is advisable to use thread-locking compounds to eyebolts and other bolts in order to avoid any possibility of loosening.

The recommended thread-locking compound is Loctite 222.

The threaded rigging points used in TL series enclosures are manufactured from zinc-plated mild steel. Therefore, and additionally if the external bolts used are zinc-plated, zinc-passivated, stainless steel or anodised (as the majority are), then the corresponding activator, Loctite 7471, should be used to achieve 100% performance.

**Application:** Spray Loctite 7471 into the thread holes and allow to evaporate. Apply Loctite 222 thread locking compound to the bolts prior to fitting, allowing sufficient to fill all the engaged threads. Assemble components and tighten as necessary.

The parts may be disassembled by hand if required.

## **APPENDIX B**

### **Spares and Accessories**

CD-106	1" HF compression driver
RD-106	Replacement diaphragm for CD-106
LS-6504	6.5" MF loudspeaker
RC-6504	Recone kit for LS-6504
LS-1211	12" LF loudspeaker
RC-1211	Recone kit for LS-1211
LS-1514	15" LF loudspeaker
RC-1514	Recone kit for LS-1514
LS-1807	18" LF loudspeaker
RC-1807	Recone kit for LS-1807
MG-1201	Metal grille for TL-1201
MG-1501	Metal grille for TL-1501
MG-1561	Metal grille for TL-1561
MG-1500	Metal grille for TL-1500
MG-1550	Metal grille for TL-1550
MG-1800	Metal grille for TL-1800
PX-1201	Passive crossover network for TL-1201
PX-1501	Passive crossover network for TL-1501
PX-1561	Passive crossover network for TL-1561
PX-1500	Passive crossover network for TL-1500
PX-1550	Passive crossover network for TL-1550
PX-1800	Passive crossover network for TL-1800

### **Flying Accessories**

EB-10	M10 x 18mm shoulder eyebolt
PA-100	35mm straight pole

**APPENDIX C**

**Technical Specifications**

	<b>TL-1201</b>	<b>TL-1501</b>	<b>TL-1561</b>
<b>Dimensions (H x W x D)</b>	<b>550mm x 395mm x 383mm (21.6" x 15.5" x 15")</b>	<b>635mm x 480mm x 465mm (25" x 18.9" x 18.3")</b>	<b>810mm x 480mm x 465mm (31.9" x 18.9" x 18.3")</b>
<b>Net weight</b>	<b>21kg (46.2lbs)</b>	<b>26kg (57.2lbs)</b>	<b>32kg (70.4lbs)</b>
<b>Components</b>	<b>1 x 12" LF driver 1 x 1" HF compression driver</b>	<b>1 x 15" LF driver 1 x 1" HF compression driver</b>	<b>1 x 15" LF driver 1 x 6.5" MF driver 1 x 1" HF compression driver</b>
<b>Frequency response</b>	<b>54Hz – 20kHz ±6dB</b>	<b>46Hz – 20kHz ±6dB</b>	<b>42Hz – 20kHz ±6dB</b>
<b>Nominal dispersion</b>	<b>70°H x 40°V @-6dB pts</b>	<b>70°H x 40°V @-6dB pts</b>	<b>70°H x 40°V @-6dB pts</b>
<b>Sensitivity</b>	<b>98dB, 1 watt @ 1metre</b>	<b>99Db, 1 watt @ 1metre</b>	<b>98dB, 1 watt @ 1 metre</b>
<b>Power handling</b>	<b>250 watts r.m.s. 500 watts program</b>	<b>300 watts r.m.s. 600 watts program</b>	<b>300 watt r.m.s. 600 watts program</b>
<b>Maximum SPL</b>	<b>122dB continuous 128dB peak</b>	<b>124dB continuous 130dB peak</b>	<b>123dB continuous 129dB peak</b>
<b>Construction</b>	<b>15mm (5/8") birch plywood</b>	<b>15mm (5/8") birch plywood</b>	<b>15mm (5/8") birch plywood</b>
<b>Grille</b>	<b>Powder coated perforated steel mesh</b>	<b>Powder coated perforated steel mesh</b>	<b>Powder coated perforated steel mesh</b>
<b>Connectors</b>	<b>(2) Speakon NL4MP wired pin 1+ positive, pin 1- negative</b>	<b>(2) Speakon NL4MP wired pin 1+ positive, pin 1- negative</b>	<b>(2) Speakon NL4MP wired pin 1+ positive, pin 1- negative</b>

Due to continuing product improvement the above specifications are subject to change.



	TL-1500	TL-1550	TL-1800
<b>Dimensions</b> (H x W x D)	530mm x 480mm x 465mm (20.9" x 18.9" x 18.3")	875mm x 480mm x 465mm (34.4" x 18.9" x 18.3")	600mm x 500mm x 485mm (23.6" x 19.7" x 19")
<b>Net weight</b>	23kg (50.6lbs)	37kg (81.4lbs)	26kg (57.2lbs)
<b>Components</b>	1 x 15" LF driver	2 x 15" LF drivers	1 x 18" LF driver
<b>Frequency response</b>	50Hz – 225Hz ±6dB	50Hz – 225Hz ±6dB	42Hz – 225Hz ±6dB
<b>Sensitivity</b>	99dB, 1 watt @ 1metre	101dB, 1 watt @ 1metre	97dB, 1 watt @ 1 metre
<b>Power handling</b>	300 watts r.m.s. 600 watts program	600 watts r.m.s. 1200 watts program	350 watt r.m.s. 700 watts program
<b>Maximum SPL</b>	122dB continuous 128dB peak	124dB continuous 130dB peak	123dB continuous 129dB peak
<b>Construction</b>	15mm (5/8") birch plywood	15mm (5/8") birch plywood	15mm (5/8") birch plywood
<b>Grille</b>	Powder coated perforated steel mesh	Powder coated perforated steel mesh	Powder coated perforated steel mesh
<b>Connectors</b>	(2) Speakon NL4MP wired pin 1+ positive, pin 1- negative	(2) Speakon NL4MP wired pin 1+ positive, pin 1- negative	(2) Speakon NL4MP wired pin 1+ positive, pin 1- negative

Due to continuing product improvement the above specifications are subject to change.

## **APPENDIX D**

### **Limited Warranty**

This Turbosound loudspeaker product is warranted to the original end-user purchaser and all subsequent owners for a period of two (2) years from the original date of purchase.

### **Warranty Coverage**

Warranty coverage includes defects in materials and workmanship. It does not include:

- damage caused by accident, misuse, abuse, neglect or modification by any person other than an authorised Turbosound representative,
- damage caused by failure to operate the product in accordance with the instructions contained in the user manual,
- damage occurring during shipment in transit,
- claims based on any misrepresentation by the seller,
- products which do not have the original components as specified in the product engineering information,
- products on which the serial number has been removed or defaced.

### **Shipping**

Should any fault develop with a component of your Turbosound system, please return the product, freight pre-paid, in its original packing carton, along with proof of purchase such as the original bill of sale or receipted invoice, and a description of the suspected fault to Turbosound Ltd. (Att: Customer Service), Star Road, Partridge Green, West Sussex RH13 8RY, England, or your local authorised Turbosound representative. The product serial number must be quoted in all correspondence relating to the claim. Insurance is recommended, as Turbosound or its representatives are not liable for loss or damage in transit. Turbosound will pay for return freight costs should repairs be covered under warranty.

**Incidental and consequential damages**

Turbosound's liability is limited to the repair or replacement, at our option, of any defective product, and shall not be liable for any incidental and consequential damages including, without limitation, injury to persons or property or loss of use.

**Limitation of implied warranties**

All implied warranties, including warranties of merchantability and fitness for a particular purpose, are limited in duration to the length of this warranty.

This warranty is in addition to, and in no way detracts from, your statutory rights as a consumer. No other warranty is expressed or implied.

Please record your purchase information below for future reference:

Dealer Name \_\_\_\_\_

Dealer Address \_\_\_\_\_

\_\_\_\_\_

\_\_\_\_\_

Post / Zip Code \_\_\_\_\_

Dealer telephone / fax \_\_\_\_\_

Invoice number \_\_\_\_\_

Date of purchase \_\_\_\_\_

Unit serial number \_\_\_\_\_

Turbosound Ltd.  
Star Road, Partridge Green  
West Sussex RH13 8RY England  
Tel: +44 (0)1403 711447 Fax: +44 (0)1403 710155  
web: [www.turbosound.com](http://www.turbosound.com)