

MAC 250 Krypton/Entour

user manual

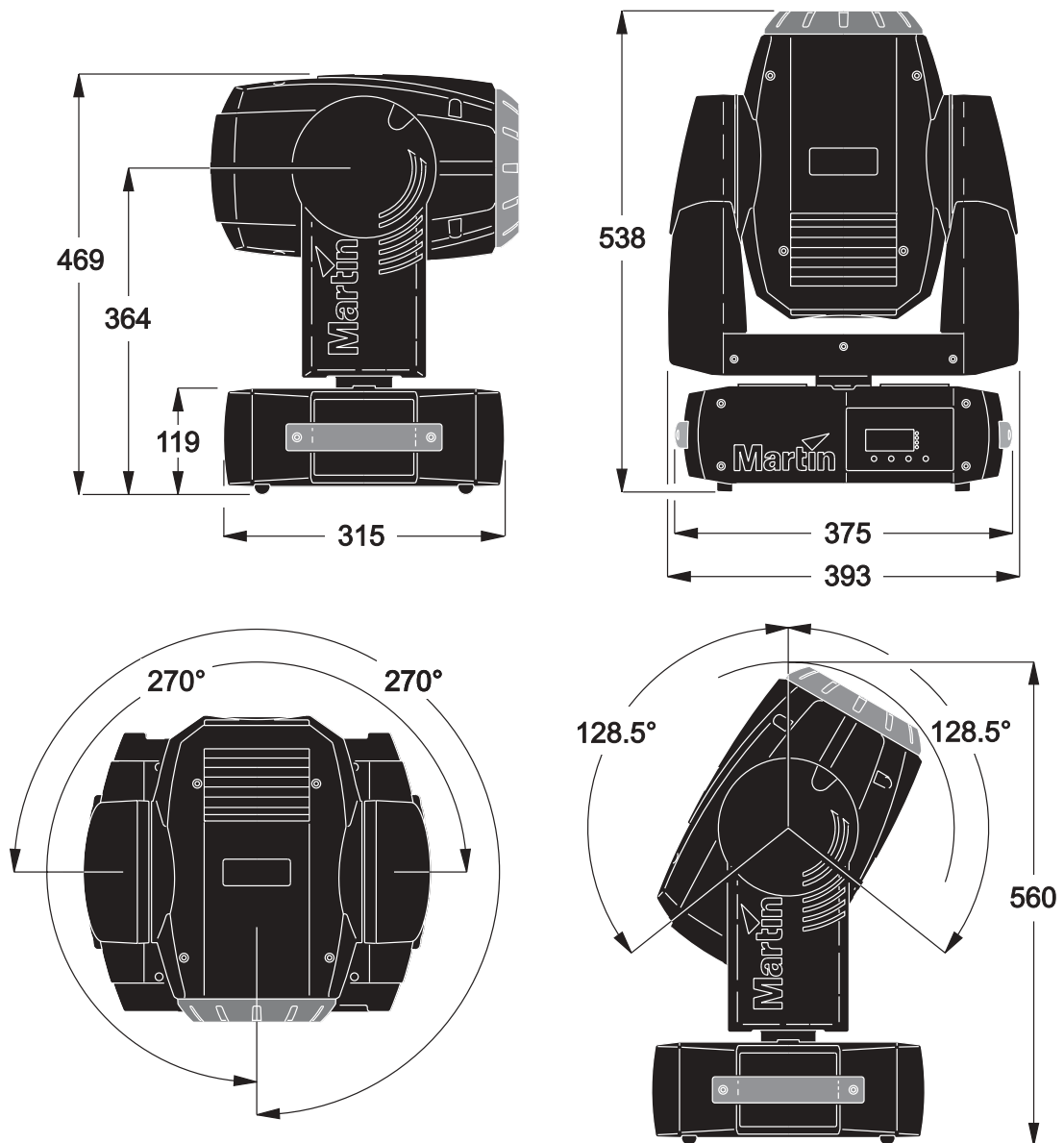

All measurements are expressed in millimeters



CONTENTS

INTRODUCTION	5
Features	5
MAC 250 Krypton/Entour safety information	5
SETUP	7
Unpacking	7
AC power	7
Installation	9
Connecting the serial data link	10
CONTROL PANEL	11
Menu navigation	11
DMX Mode selection	11
DMX Address selection	11
Tailoring performance	11
Information readouts	12
Test and service utilities	13
DMX-512 CONTROL	15
Lamp power	15
Effect position	15
Speed control	16
OPTICAL CONFIGURATION	18
Rotating gobos	18
Fixed gobos (MAC 250 Entour only)	21
Color filters	22
Prism	23
Mounting the optional 14° lens (MAC 250 Entour only)	27
SERVICE	30
Lamp replacement	30
Cleaning	31
Lubrication	32
Replacing fuses	32
Updating software	33
DMX PROTOCOL	34
MAC 250 Krypton DMX protocol	35
MAC 250 Entour DMX protocol	38
CONTROL MENU	41
ERROR MESSAGES	45
TROUBLESHOOTING	46
CIRCUIT BOARD CONNECTIONS	47
SPECIFICATIONS - MAC 250 KRYPTON	48
SPECIFICATIONS - MAC 250 ENTOUR	50

INTRODUCTION

Thank you for selecting the Martin MAC 250 Krypton or the MAC 250 Entour.

Features

Some of the many features include:

- efficient, 3000 hour, 250 watt discharge lamp
- 12 interchangeable dichroic colors
- 7 interchangeable indexed-rotation gobos
- interchangeable 3-facet rotating prism
- motorized focus
- full-range dimming
- fast blackout and strobe effects
- coated optics
- user-installable firmware
- switch-selectable power supply settings

The MAC 250 Entour additionally features:

- 10 fixed gobos
- Tilt locks
- Optional lens providing a 14° beam angle

For the latest firmware updates, documentation, and other information about this and all Martin Professional products, please visit the Martin web site at <http://www.martin.dk>.

Please check the Martin web site at <http://www.martin.dk> for the latest product software and documentation.

Comments or suggestions regarding this document may be e-mailed to service@martin.dk or posted to

Martin Professional A/S
Olof Palmes Allé 18
DK-8200 Aarhus N, Denmark
Attn: Service Department

Please review the important safety precautions in this manual before installing and operating the fixture.

MAC 250 Krypton/Entour safety information

Warning! *This product is for professional use only. It is not for household or residential use.*

This product presents risks of lethal or severe injury due to fire and heat, electric shock, ultraviolet radiation, lamp explosion, and falls. **Read this manual** before powering or installing the fixture, follow the safety precautions listed below and observe all warnings in this manual and printed on the fixture. If you have questions about how to operate the fixture safely, please contact your Martin dealer or call the Martin 24-hour service hot line at +45 70 200 201.

PROTECTION FROM ELECTRIC SHOCK

Warning! *Always disconnect from mains supply before replacing the lamp.*

- Disconnect the fixture from AC power before removing or installing the lamp, fuses, or any part, and when not in use.
- Always ground (earth) the fixture electrically.

- Use only a source of AC power that complies with local building and electrical codes and has both overload and ground-fault protection.
- Do not expose the fixture to rain or moisture.
- Refer any service operation not described in this manual to a qualified technician.

PROTECTION FROM UV RADIATION AND LAMP EXPLOSION

- Never operate the fixture with missing or damaged lenses and/or covers.
- When replacing the lamp, allow the fixture to cool for at least 15 minutes before opening the fixture or removing the lamp. Protect your hands and eyes with gloves and safety glasses.
- Do not stare directly into the light. Never look at an exposed lamp while it is lit.
- Replace the lamp if it becomes defective or worn out, or before usage exceeds the maximum service life.

PROTECTION FROM BURNS AND FIRE

Danger! *Intense heat. Avoid contact by persons and materials.*

The exterior of the fixture can get very hot - up to 120° C (248° F). Allow the fixture to cool for at least 45 minutes before handling.

Prolonged exposure to unshielded lamp can cause eye and skin burns.

- Never attempt to bypass the thermostatic switch or fuses. Always replace defective fuses with ones of the specified type and rating.
- Keep all combustible materials (for example fabric, wood, paper) at least 1 meter (39 inches) away from the fixture. Keep flammable materials well away from the fixture.
- Do not illuminate surfaces within 3 meters (10 feet) of the fixture.
- Provide a minimum clearance of 0.1 meters (4 inches) around fans and air vents.
- Never place filters or other materials over the lens.
- Do not modify the fixture or install other than genuine Martin parts.
- Do not operate the fixture if the ambient temperature (Ta) exceeds 40° C (104° F). Protection from injury due to falls
- Do not lift or carry the fixture alone.
- When suspending the fixture, verify that the structure can hold at least 10 times the weight of all installed devices.
- Verify that all external covers and rigging hardware are securely fastened and use an approved means of secondary attachment such as a safety cable.
- Block access below the work area whenever installing or removing the fixture.

SETUP

Unpacking

The MAC 250 Krypton/Entour comes with:

- MSD 250/2 lamp (factory installed)
- 3-meter, 3-wire IEC power cable
- user manual
- 1/4-turn clamp mounting bracket
- 5-meter, 3-pin shielded XLR control cable

The MAC 250 Entour also comes with an extra 14° lens.

The packing material or flightcase is carefully designed to protect the fixture during shipment - always use it to transport the fixture.

When installing the MAC 250 Entour model you may find it useful to lock the head in place using the tilt locks.

AC power

Warning! *For protection from electric shock, the fixture must be grounded (earthed). The power supply shall have overload and ground-fault protection.*

Important! *Verify that power supply settings match the local AC supply before use.*

The MAC 250 Krypton/Entour is factory configured for 230 V / 50 Hz operation. If your AC power supply is different, the fixture must be configured for the local voltage and frequency. Always use the settings that are closest to your AC supply.

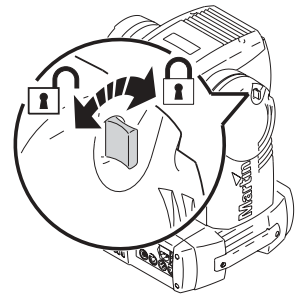

CONFIGURING FOR LOCAL AC POWER

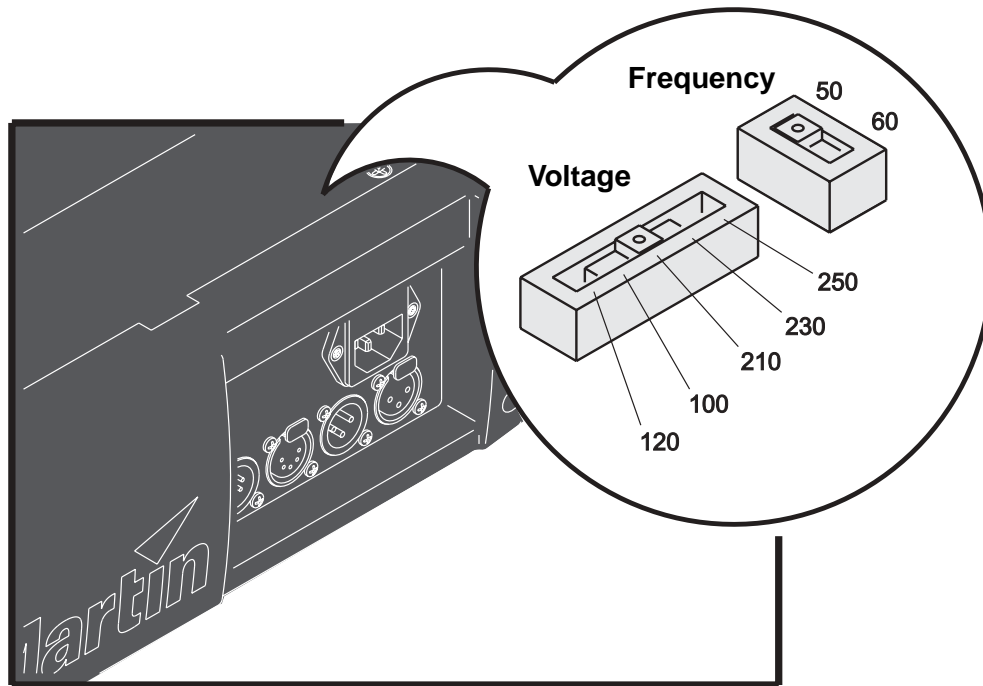

Figure 1: Power supply settings

- 1 Disconnect the fixture from power.
- 2 Remove the 2 Phillips screws in the access cover directly behind the power and data connectors. Lift off the cover.
- 3 Locate the selection switches.
- 4 Move the voltage switch to the setting that most closely matches the local AC voltage. If your voltage falls halfway between 2 settings, select the higher voltage. For example, if the AC voltage is 220 V, use the 230 V setting instead of 210 V.
- 5 Move the frequency switch to the setting that matches the local AC frequency: 50 or 60 Hz.
- 6 Replace the cover.

INSTALLING A PLUG ON THE POWER CABLE

The power cable must be fitted with a grounding-type cord cap that fits your power distribution system. Consult an electrician if you have any doubts about proper installation.

- Following the cord cap manufacturer's instructions, connect the yellow and green wire to ground (earth), the brown wire to live, and the blue wire to neutral. The table below shows some pin identification schemes.

Wire	Pin	Marking	Screw color
brown	live	"L"	yellow or brass
blue	neutral	"N"	silver
yellow/green	ground		green

Table 1: Plug wiring

APPLYING POWER

Warning! *The power cables must be undamaged and rated for the electrical requirements of all connected devices.*

Important! *Powering through a dimmer system can damage the fixture.*

- 1 Verify that the supply cable is undamaged and rated for the current requirements of all connected devices.
- 2 Plug the prepared power cable into the AC socket and a grounded AC power supply.

Installation

LOCATION AND ORIENTATION

The MAC 250 Krypton/Entour may be installed in any orientation. It can be fastened directly to a suitable surface, hung with a rigging clamp, or placed directly on a level surface.

For safe operation, install the MAC 250 Krypton/Entour in a location where:

- the fixture is at least 1 meters (39 inches) away from combustible materials
- the fixture is protected from rain and moisture
- there is at least 0.1 meters (4 inches) clearance around the fan and control panel
- there are no flammable materials nearby

RIGGING OR MOUNTING THE MAC 250 KRYPTON/ENTOUR

Warning! *Block access below the work area before proceeding.*

The MAC 250 Krypton/Entour can be placed on stage or clamped to a truss in any orientation. The Fast-Lock system enables quick and easy fastening of the clamp brackets in 4 positions.

The MAC 250 Krypton/Entour includes an omega clamp mounting bracket to which 1 or 2 rigging clamps (not included) can be bolted. The clamp mounting bracket fastens to the base as shown with 1/4-turn fasteners.

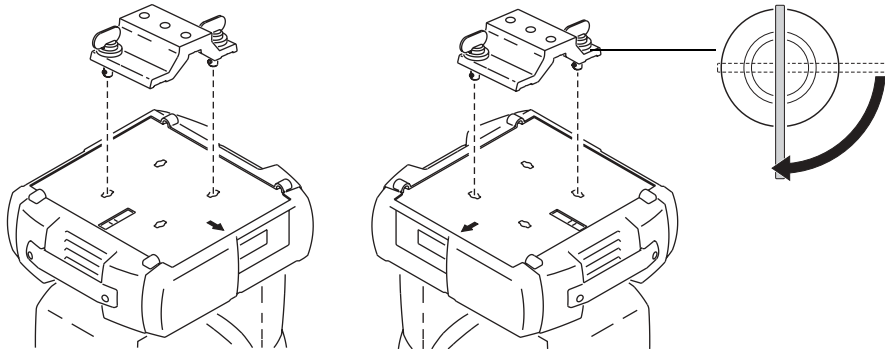

Figure 2: Clamp mounting bracket

Warning! *Attach an approved safety cable to the attachment point provided in the base. Never use the carrying handles for secondary attachment. Always use an approved safety cable.*

The 1/4-turn fasteners are locked only when turned fully clockwise.

- 1 Verify that the clamps are in good condition and can bear at least 10 times the weight of the fixture. Bolt clamps to the bracket with a grade 8.8 (minimum) M12 bolt and lock nut, or as recommended by the clamp manufacturer, through the 13 mm holes in the clamp mounting bracket.
- 2 Align the clamp mounting bracket with any 2 key slots on the base. Insert both locking pins into the slots and turn both levers a full 1/4 turn clockwise to lock.
- 3 Verify that the structure can bear at least 10 times the weight of all installed fixtures, clamps, cables, auxiliary equipment, etc.
- 4 Working from a stable platform, clamp the fixture to the structure.

- 5 Install a safety cable that can bear at least 10 times the weight of the fixture securely to the structure and anchor the cable to the dedicated attachment point on the base. The attachment point is designed to fit a carabiner clamp.

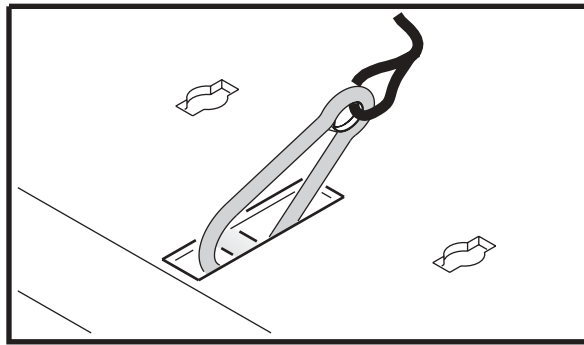

- 6 Verify that there are no combustible materials or surfaces to be illuminated within 1 meter (39 inches) of the fixture, and that there are no flammable materials nearby.

Connecting the serial data link

The MAC 250 Krypton/Entour has locking 3-pin and 5-pin data input and output sockets that are wired for use with DMX devices with pin 1 to shield, pin 2 to cold (-) and pin 3 to hot (+).

Important! *Never connect more than 1 data input and 1 data output.*

- 1 Connect the controller's output to the fixture's data input.
- 2 Connect the output of the fixture closest to the controller to the input of the next fixture. If connecting a fixture with pin 3 hot to a fixture with pin 3 cold, use a phase-reversing adaptor.
- 3 To terminate the link, insert a male 120 Ω XLR termination plug in the output of the last fixture.

TIPS FOR BUILDING A SERIAL LINK

- Use shielded twisted-pair cable designed for RS-485 devices: standard microphone cable cannot transmit DMX data reliably over long runs. For links up to 300 meters (1000 ft.) long, you can use 24 AWG, low capacitance, 85-150 ohm characteristic impedance, shielded cable with 1 or more twisted pairs. For runs up to 500 meters (1640 ft.) use 22 AWG cable. Use an amplifier if the serial link exceeds 500 meters.
- Never use a "Y" connector to split the link. To split the serial link into branches use a splitter such as the Martin 4-Channel Opto-Isolated RS-485 Splitter/Amplifier.
- Do not overload the link. Up to 32 devices may be connected on a serial link.
- Terminate the link by installing a termination plug in the output socket of the last fixture on the link. The termination plug, which is simply a male XLR connector with a 120 ohm, 0.25 watt resistor soldered between pins 2 and 3, "soaks up" the control signal so it does not reflect back down the link and cause interference. If a splitter is used, terminate each branch of the link.

CONTROL PANEL

You set the address and personalities, read out data, and execute service utilities from the control panel. Settings can also be changed remotely via the serial link with the Martin MP-2 uploader.

See also the control menu table starting on page 39.

Menu navigation

The DMX address and any error messages are displayed after the fixture resets. To enter the menu, press [menu]. Use the [up] and [down] keys to move within the menu. To select a function or submenu, press [enter]. To escape a function or menu, press [menu].

DMX Mode selection

The fixture has two DMX operating modes, 16-bit and 16-bit Extended. 16-bit Extended mode uses 17 DMX channels, three more than the 14 DMX channels than standard 16-bit mode requires. 16-bit Extended mode provides more precise control of the dimmer color, and focus settings. The DMX mode is selected using the PSET option in the fixture control menu (see “Control menu” on page 39).

SETTING THE DMX MODE

- 1 Apply power to the MAC 250 Krypton/Entour. Press [menu] to enter the main menu.
- 2 Select PSET using the [up] and [down] keys. Press [enter].
- 3 Select 16BT for standard 16-bit mode, or 16EX for 16-bit extended mode. Press [enter].
- 4 Press [menu] to return to the main menu.

DMX Address selection

For independent control, each fixture must be assigned its own address and non-overlapping control channels. Two MAC 250 Krypton/Entours can share the same address if they are to respond identically: they will receive the same instructions and individual control will not be possible.

SETTING THE DMX ADDRESS

- 1 Apply power to the MAC 250 Krypton/Entour. Press [menu] to enter the main menu.
- 2 Select AddR using the [up] and [down] keys. Press [enter].
- 3 Select an address (start channel) from 1 to 500 using the [up] and [down] keys. Press [enter]. Press [menu] to return to the main menu.

Tailoring performance

MOVEMENT

The MAC 250 Krypton/Entour provides the three menus with options for optimizing movement to suit different applications.

- **PATI**, the pan and tilt invert menu, allows you to swap the pan and tilt channels (**SWAP>ON**), invert pan movement (**PINV>ON**), and invert tilt movement (**TINV>ON**). These options can be useful in situations where you want some fixtures to mirror the performance of others with the same DMX address, or when fixtures are not oriented as programmed.

- **PTSP**, the pan/tilt speed menu, provides 3 settings: **FAST**, **NORM** and **SLOW**. **NORM** is best for most applications. **FAST** provides better performance in applications where speed is most important.
- **SCUT**, the shortcuts setting which can be found under the **PERS** (personality) menu, determines whether the color and gobo wheels scroll past open when changing positions. When set to **ON**, the wheels can “take a shortcut” and scroll through open when this is the shortest path to the next position. The wheels do not scroll past open when **SCUT** is set to **OFF**.

DISPLAY

The display menu (**PERS>dISP**) determines whether the display remains lit or not. Select **ON** to have the display remain lit, or **OFF** to extinguish the display two minutes after the last key press.

To flip the display for easier reading, press [up] and [down] simultaneously.

The display intensity setting (**PERS>dINT**) controls display brightness. You can select **AUTO** for automatic dimming of the display using the built-in light sensor, or manually select an intensity level from 10 to 100.

LAMP POWER

There are two settings that modify lamp control: Automatic Lamp On (**PERS>ALON**) and DMX Lamp-Off (**PERS>DLOF**).

There are three options for automatic lamp control: **ON**, **OFF**, and **DMX**. When **ALON** is **OFF**, the lamp remains off until a lamp-on command is received from the controller. When **ALON** is **ON**, the lamp strikes automatically after the fixture is powered on. When **ALON** is set to **DMX**, the lamp strikes automatically when the fixture receives DMX data, and it extinguishes automatically 15 minutes after DMX data is lost. When **ALON** is either **ON** or **DMX**, lamp strike timing is determined by the fixture address to prevent all lamps from striking at once.

The DMX Lamp-Off setting effects how the lamp can be turned off. When **dLOF** is **ON**, lamp power can be switched off by sending a DMX value from 248 to 255 on channel 1 for five seconds. When **dLOF** is **OFF**, the lamp-off command will not work unless special conditions are met. Refer to the DMX protocol.

RESET

The fixture can be reset from the controller if DMX reset (**PERS>dRES**) is set to **5SEC**. If DMX reset is **OFF**, this command will not work unless special conditions are met. Refer to the DMX protocol.

DEFAULT SETTINGS

The fixture can be reset to its factory default settings by selecting **dFSE>FACT>LOAD**.

Information readouts

POWER-ON HOURS

Read the total number of hours the fixture has been on since fabrication (**INFO>TIME>HRS>TOTL**), and the number of hours on since the counter was last reset (**INFO>TIME>HRS>RSET**). This can be used to track maintenance intervals. Press [up] for 5 seconds while displayed to reset.

LAMP HOURS

Read the total number of lamp hours since fabrication (**INFO>TIME>L HR>TOTL**), and the number of lamp hours since the counter was last reset (**INFO>TIME>L HR>RSET**). Reset this counter after installing a new lamp. Press [up] for 5 seconds while displayed to reset.

LAMP STRIKES

Read the total number of lamp strikes (**INFO>TIME>L ST>TOTL**), and the number of lamps strikes since the counter was last reset (**INFO>TIME>L ST>RSET**). Reset this counter when installing a new lamp. Press [up] for 5 seconds while displayed to reset.

FIRMWARE VERSION

`INFO>VER` displays the firmware version number. The firmware version is also displayed briefly at startup.

Test and service utilities

DMX READOUT

The DMX log (`dMXL`) menu provides useful information for troubleshooting control problems.

`RATE` displays the DMX refresh rate in packets per second. Values lower than 10 or higher than 44 may result in erratic performance, especially when using tracking control.

`QUAL` displays the quality of the received DMX data as a percentage of packets received. Values much below 100 indicate interference, poor connections, or other problems with the serial data link that are the most common cause of control problems.

`STCO` displays the DMX start code. Packets with a start code other than 0 may cause irregular performance.

The remaining options under `dMXL` display the DMX values received on each of the 13 channels, from `SHUT` (shutter, channel 1) to `EFSP` (effect speed, channel 13). If the fixture does not behave as expected, reading the DMX values can help you troubleshoot the problem.

MANUAL CONTROL

The manual control menu (`MAN`) provides commands for turning the lamp on (`LON`), turning the lamp off (`LOFF`), and resetting the fixture (`RST`). It also permits you to position and move individual effects.

EFFECTS TEST

The test sequence (`TSEQ>RUN`) runs through all effects to provide a quick check of fixture performance. Note: the test sequence does not automatically strike the lamp. Use `MAN>LON` and `MAN>LOFF` to control lamp power. Press [menu] to stop the test.

FEEDBACK TOGGLE

Magnetic sensors monitor the positions of the color wheel, gobo wheel, and rotating gobos. If they detect an error, the shutter closes while the effect resets. This feature can be disabled by turning effects feedback off (`UTIL>EFFb>OFF`).

ADJUSTMENT POSITIONS

The adjustment menu (`UTIL>AdJ`) provides commands for positioning effects during mechanical adjustment.

EFFECT CALIBRATION

With the calibration menu (`UTIL>CAL`), effect positions can be fine-tuned with a software-defined offset value to compensate for small misalignments or differences between fixtures.

The default offset command (`UTIL>dFOF`) erases any offsets stored in memory.

CIRCUIT BOARD TEST

`UTIL>PCBT` executes a routine designed for testing the main circuit board. For service use only.

UPLOAD MODE

The upload mode command (`UTIL>UPLd`) prepares the fixture for a software update. This command is not necessary, however, as upload mode is engaged automatically by the uploader.

DMX-512 CONTROL

The MAC 250 Krypton/Entour is compatible with USITT DMX512 controllers.

The full protocol is available in “DMX protocol” on page 32.

The fixture has two DMX operating modes, 16-bit and 16-bit Extended. 16-bit Extended mode uses 17 DMX channels, three more than the 14 DMX channels than standard 16-bit mode requires. 16-bit Extended mode provides more precise control of the dimmer color, and focus settings. All other functions are identical. See “DMX protocol” on page 25. This section briefly describes the DMX-controllable effects. The DMX mode is selected using the PSET option in the fixture control menu (see “Control menu” on page 39).

Lamp power

LAMP-ON

Unless automatic lamp strike is enabled, lamp power remains off until a lamp-on command is sent from the controller.

Note: A peak of electric current that can be many times the operating current is drawn for an instant when striking a discharge lamp. Striking many lamps at once may cause a voltage drop large enough to prevent lamps from striking or draw enough current to trip circuit breakers. If sending lamp-on commands to multiple fixtures, program a sequence that strikes lamps one at a time at 5 second intervals.

LAMP-OFF

The lamp can be turned off from the controller by sending the lamp-off command on channel 1 for 5 seconds. ***The lamp cannot be restruck for 8 minutes after being turned off.*** Note that the lamp-off command may be disabled by the DMX Lamp-Off personality setting (PERS/dLOF).

Effect position

RESET

If an effect loses its indexing and fails to move to programmed positions, the fixture can be reset from the controller by sending the “Reset” command on channel 1 for 5 seconds. Note that the DMX reset feature may be disabled by the DMX Reset personality setting (PERS/dRES).

DIMMER / SHUTTER

The mechanical dimmer/shutter system provides full, high-resolution dimming, “instant” open and blackout, random and variable strobe effects, and random and variable pulses in which the dimmer snaps open and slowly dims or snaps closed and slowly opens. Shutter, strobe, and pulse effects are selected on channel 1. The intensity level is selected on channel 2. 16-bit Extended mode provides fine tuning of the intensity level on channel 3.

COLOR

The color wheel can be scrolled continuously - allowing for split color effects - or in steps, and rotated randomly or continuously in both directions at different speeds. 16-bit Extended mode provides finer tuning on channel 5 of the color setting selected on channel 4.

ROTATING GOBOS

The MAC 250 Krypton/Entour has 7 indexed-rotation gobo positions plus an open position. Gobos can be indexed (positioned at a defined angle), rotated continuously, or rotated and shaken (bounced). The gobo and the type of movement are selected on channel 4 (channel 6 in 16-bit Extended mode) and the index

angle or rotation speed are selected on channel 5 (channel 7 in 16-bit Extended mode). Fine tuning of this index position or rotation is available on channel 6 (channel 8 in 16-bit Extended mode).

The gobo wheel can also rotate continuously in both directions at variable speed.

FIXED GOBOS (MAC 250 ENTOUR ONLY)

The MAC 250 Entour provides an additional wheel with 10 fixed gobo positions (plus open). The gobo and the type of movement are selected on channel 7 (channel 9 in 16-bit Extended mode). The gobo wheel can also rotate continuously in both directions at variable speed.

FOCUS

The beam may be focused from approximately 2 meters (6.5 feet) to infinity using channel:

- 7 in 16-bit mode on the MAC 250 Krypton
- 9 in 16-bit Extended mode on the MAC 250 Krypton
- 8 in 16-bit mode on the MAC 250 Entour
- 10 in 16-bit Extended mode on the MAC 250 Entour

ROTATING PRISM

The prism is controlled using channel:

- 8 in 16-bit mode on the MAC 250 Krypton
- 10 in 16-bit Extended mode on the MAC 250 Krypton
- 9 in 16-bit mode on the MAC 250 Entour
- 11 in 16-bit Extended mode on the MAC 250 Entour

The prism may be inserted and removed from the light path. It rotates in both directions at varying speeds.

PAN AND TILT

Head pan and tilt are controlled on channels

- 9-12 in 16-bit mode on the MAC 250 Krypton
- 12-15 in 16-bit Extended mode on the MAC 250 Krypton
- 10-13 in 16-bit mode on the MAC 250 Entour
- 13-16 in 16-bit Extended mode on the MAC 250 Entour

The course control channel sets first 8 bits (the most significant byte or MSB), and the fine channel sets the second 8 bits (the least significant byte or LSB) of the 16-bit control byte. In other words, the fine channel fine-tunes the position set by the course channel.

Speed control

The speed control channels are:

- 13 & 14 in 16-bit mode on the MAC 250 Krypton
- 16 & 17 in 16-bit Extended mode on the MAC 250 Krypton
- 14 & 15 in 16-bit mode on the MAC 250 Entour
- 17 & 18 in 16-bit Extended mode on the MAC 250 Entour

TRACKING CONTROL

Tracking control for pan/tilt and the various effects is enabled by setting the speed channels to 0.

With tracking control, the speed at which effects move is determined by the cross-fade time between two positions or scenes. The controller divides the move into steps and updates the fixture with small changes at the rate required to achieve the fade. The fixture "tracks" the changes and averages them with a digital filter algorithm to provide smooth movement.

VECTOR CONTROL

Alternatively, with vector control, movement speed is determined by the selected speed values on the speed channels. This provides a way to control speed on controllers without cross-faders. Vector control also

provides smoother movement, particularly at slow speeds, with controllers that send slow or irregular tracking updates.

When using vector control, the cross-fade time must be 0.

BLACKOUT

When “blackout while moving” is selected on the speed channels, the shutter closes when the effect moves to make the transition invisible. The shutter opens when the movement is complete.

PERSONALITY OVERRIDES

The following channels provide tracking values that allow you to override the pan/tilt speed personality setting (PTSP in the control menu)

- 13 in 16-bit mode on the MAC 250 Krypton
- 16 in 16-bit Extended mode on the MAC 250 Krypton
- 14 in 16-bit mode on the MAC 250 Entour
- 17 in 16-bit Extended mode on the MAC 250 Entour

The following channels provide tracking values that allow you to override the shortcuts setting (SCUT in the control menu).

- 14 in 16-bit mode on the MAC 250 Krypton
- 17 in 16-bit Extended mode on the MAC 250 Krypton
- 15 in 16-bit mode on the MAC 250 Entour
- 18 in 16-bit Extended mode on the MAC 250 Entour

OPTICAL CONFIGURATION

GOBO ORIENTATION

Figure 3 shows the correct orientation for different gobo types. When in doubt, install gobos with the more reflective side towards the lamp.

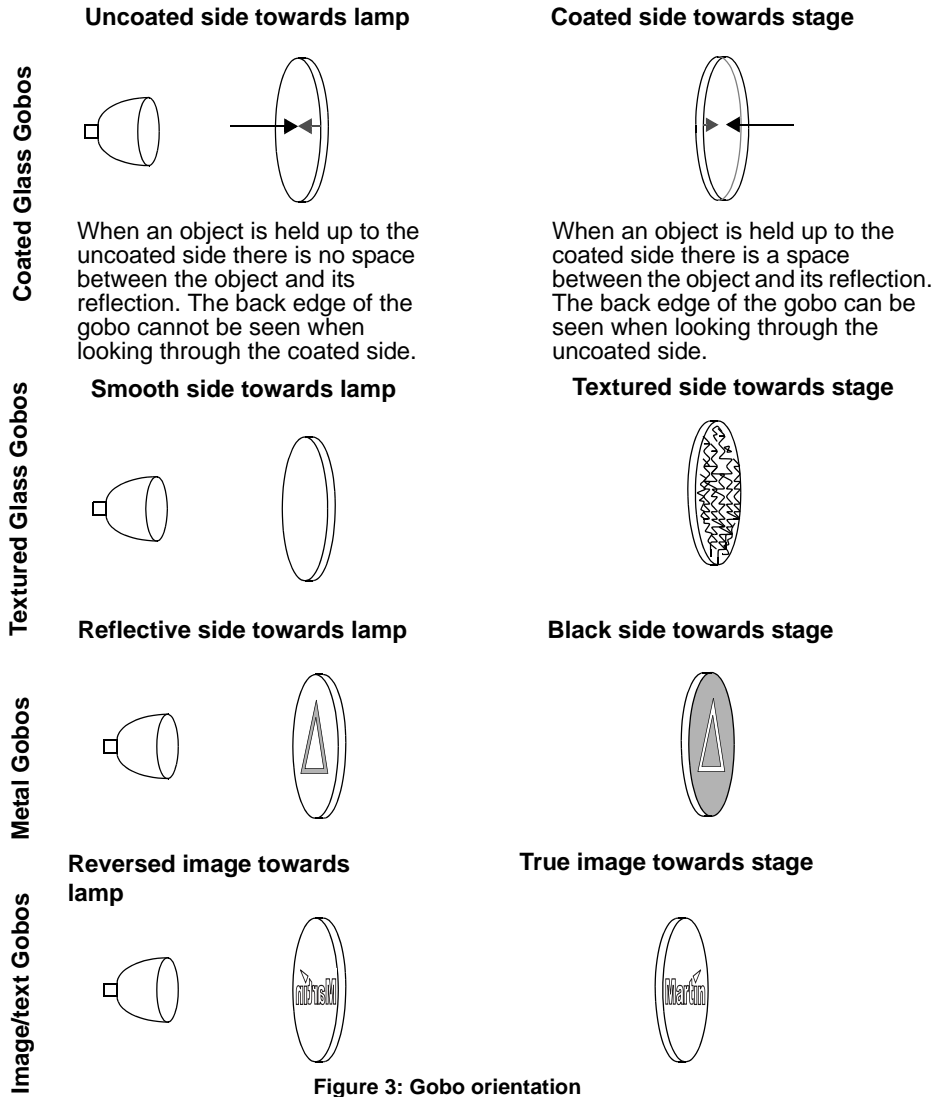

Figure 3: Gobo orientation

CUSTOM GOBOS

For optimum performance, custom glass gobos for the MAC 250 Krypton/Entour should be made with the text, logo, and similar artwork reversed on the coated side. Gobo types and dimensions are specified in on "Gobos" on page 46.

Rotating gobos

The MAC 250 Krypton/Entour accepts up to eight metal or glass gobos with an outside diameter of 22.5 mm and a maximum image diameter of 17 mm.

STANDARD ROTATING GOBO CONFIGURATION

The MAC 250 Krypton/Entour provides 7 gobos as shown below.

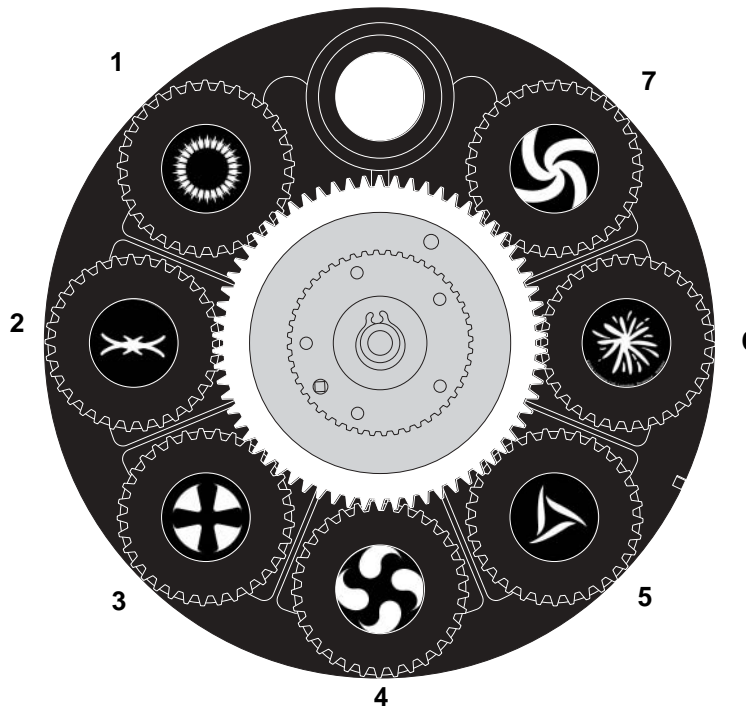

Figure 3: MAC 250

Position	Gobo
1	Eclipse
2	Fat bar
3	Fan
4	Happy Yins
5	Twisted triangle
6	Splash
7	Aflobet

Table 2: Rotating gobos

REPLACING A GOBO

Danger! *Intense heat. Avoid contact by persons and materials. The exterior of the fixture can get very hot - up to 120° C (248° F). Disconnect the fixture from AC power and allow it to cool for at least 45 minutes before handling.*

Do not removing covers while the fixture is powered on as this exposes dangerous live electrical circuits, hot surfaces, and a lamp under high pressure.

- 1 Disconnect the fixture from AC power and allow it to cool.
- 2 Remove the top cover of the fixture head using a flathead screwdriver to loosen the four quarter-turn screws. The top and bottom cover look the same, but the top cover is found by checking if the text on the back of the head is oriented correctly (top) or not (bottom) as illustrated here.

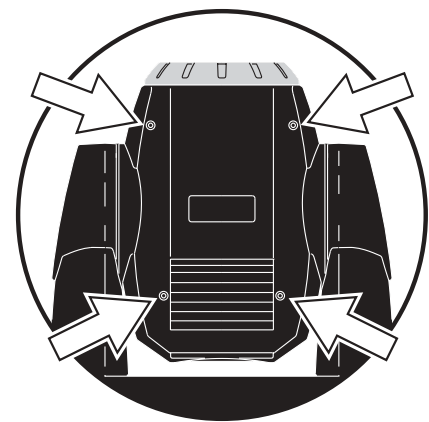
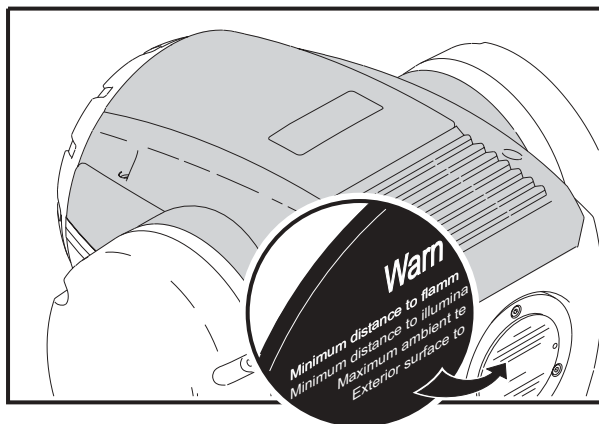

- 3 Turn the gobo wheel to access the desired position.

- 4 Remove the gobo holder from the gobo wheel.

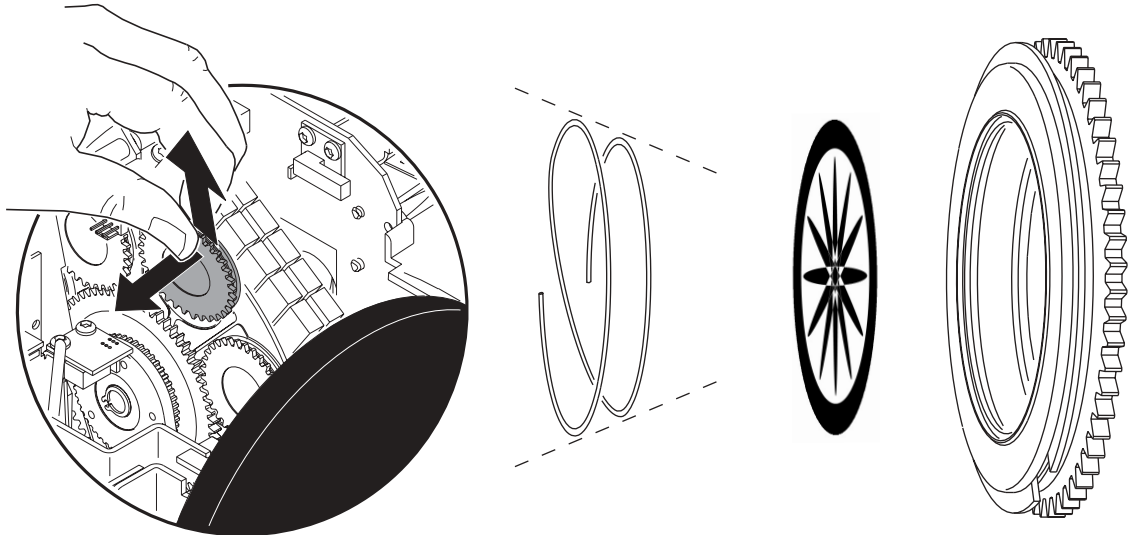

- 5 Squeeze the ends of the retention spring together and remove. Push the gobo out from the back and remove.
- 6 Orient the gobo as shown in “Gobo orientation” on page 17 and insert the replacement gobo into the holder. Secure the gobo with the retention spring.
- 7 Insert the gobo holder back in the gobo wheel using a small flathead screwdriver to lift the retaining blades.

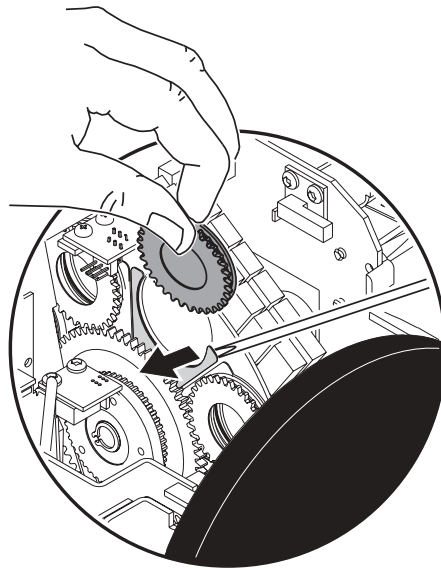

- 8 Replace the cover before applying power.

Fixed gobos (MAC 250 Entour only)

The MAC 250 Entour provides 10 fixed gobo positions (plus open).

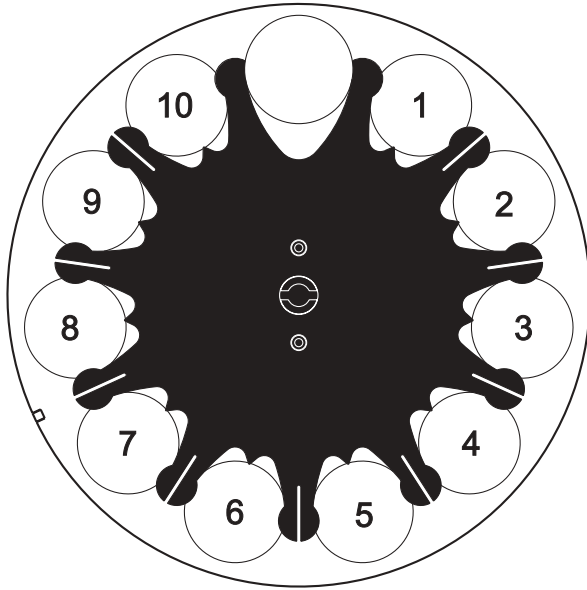

Position	Gobo
1	Oriental fire
2	Wiggles
3	Pear drops
4	Brush strokes
5	Lashes
6	Splash
7	Crazed
8	Dibs
9	Sharp breakup (large)
10	Zeds-a-leaping

Table 3: Fixed gobos

REPLACING A FIXED GOBO

Danger! *Intense heat. Avoid contact by persons and materials. The exterior of the fixture can get very hot - up to 120° C (248° F). Disconnect the fixture from AC power and allow it to cool for at least 45 minutes before handling.*

Do not removing covers while the fixture is powered on as this exposes dangerous live electrical circuits, hot surfaces, and a lamp under high pressure.

- 1 Disconnect the fixture from AC power and allow it to cool.
- 2 Remove the top cover of the fixture head using a flathead screwdriver to loosen the four quarter-turn screws. The top and bottom cover look the same, but the top cover is found by checking if the text on the back of the head is oriented correctly (top) or not (bottom) as illustrated here.

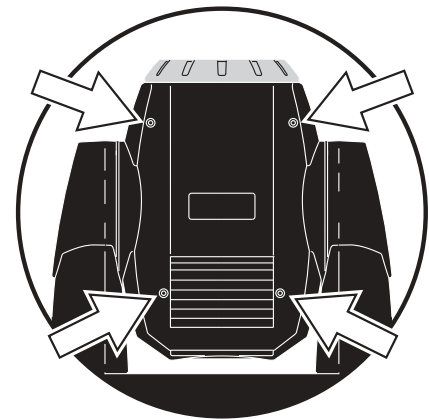
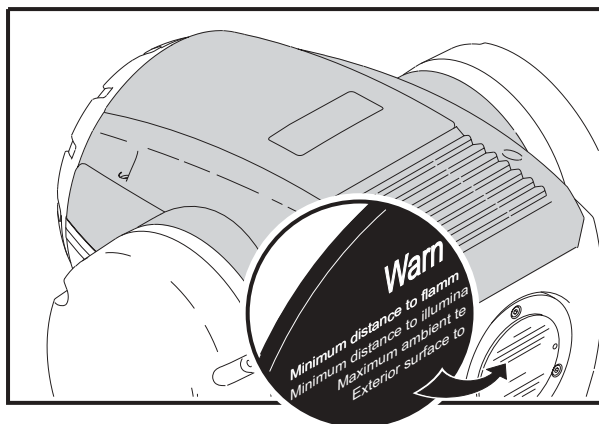

- 3 Turn the gobo wheel to access the desired position.

- 4 Push and slide the gobo out of position

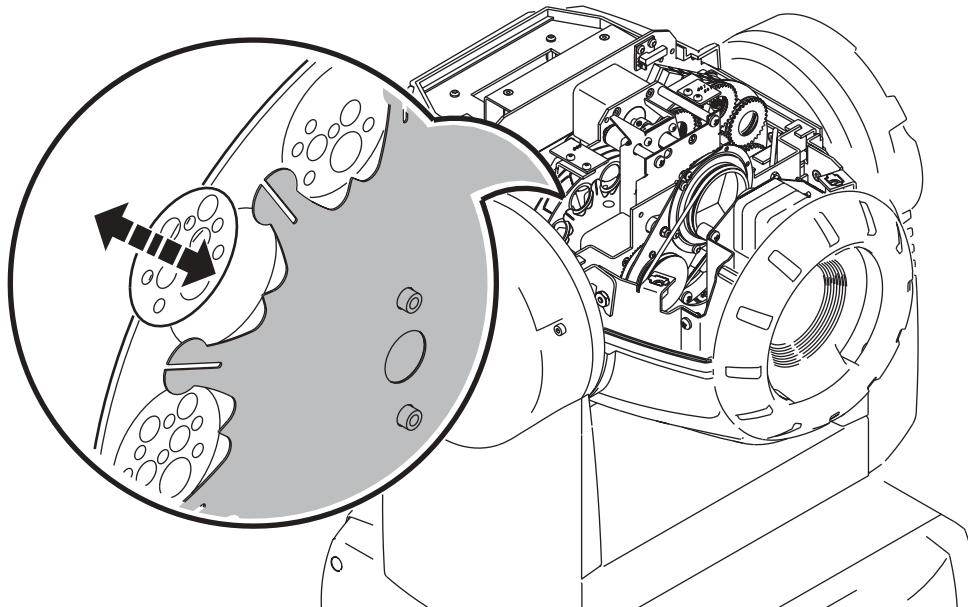

- 5 Insert the replacement gobo into the holder. Secure the gobo with the retention feather. You may find it easiest to do this with the assistance of a flathead screwdriver.
- 6 Replace the cover before applying power.

Color filters

STANDARD CONFIGURATION

The MAC 250 Krypton/Entour provides 12 dichroic color filters as shown below.

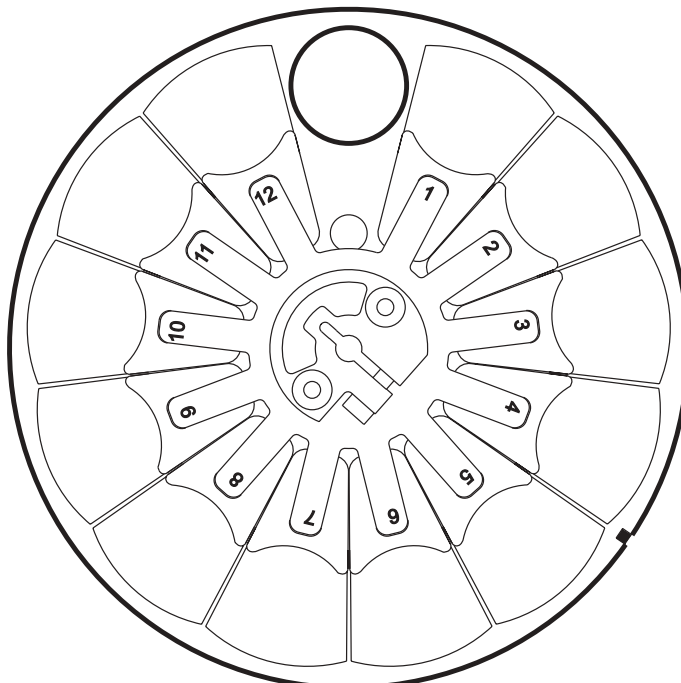

Position	Color
1	CTC
2	Yellow 603
3	Blue 104
4	Pink 312
5	Green 206
6	Blue 108
7	Red 301
8	Magenta 507
9	Blue 101
10	Orange 306
11	Dark green
12	Purple 502

Figure 5: MAC 250

REPLACING A COLOR FILTER

Danger! *Intense heat. Avoid contact by persons and materials. The exterior of the fixture can get very hot - up to 120° C (248° F). Disconnect the fixture from AC power and allow it to cool for at least 45 minutes before handling.*

Do not removing covers while the fixture is powered on as this exposes dangerous live electrical circuits, hot surfaces, and a lamp under high pressure.

- 1 Disconnect the fixture from AC power and allow it to cool.
- 2 Remove the top cover. The top and bottom cover look the same, but the top cover is found by checking if the text on the back of the head is oriented correctly (top) or not (bottom). Remove the top cover of the fixture head using a flathead screwdriver to loosen the four quarter-turn screws. The top and bottom cover look the same, but the top cover is found by checking if the text on the back of the head is oriented correctly (top) or not (bottom) as illustrated here.

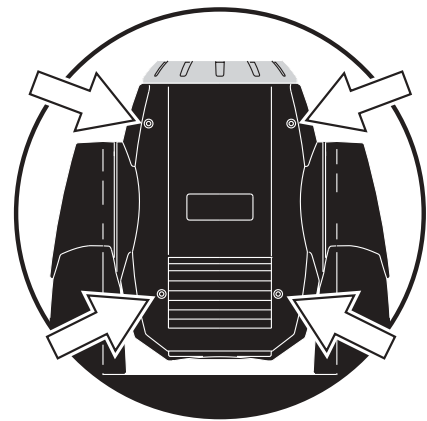
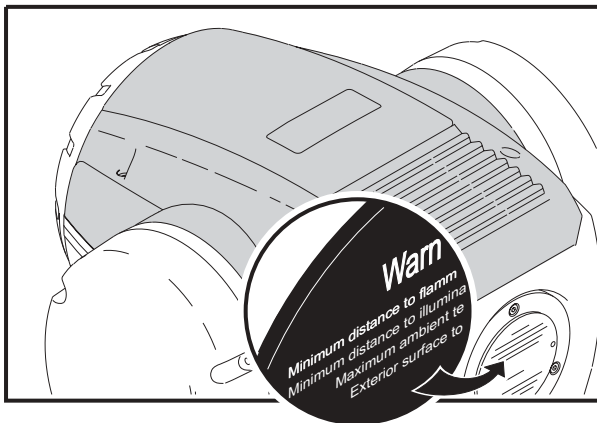

- 3 Turn the color wheel to access the desired color filter. Press the filter forwards slightly to release it and then grasp it by the edges and remove.
- 4 To insert a filter, slide it under the retention spring until it snaps into place.
- 5 Replace the top cover before applying power.

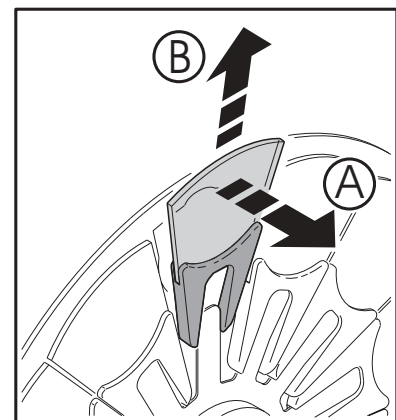

Figure 4: Filter replacement

Prism

The standard 3-facet prism can be replaced with optional five- and nine-facet prisms. See "Accessories" on page 47 for part numbers. See:

- Replacing the prism in a MAC 250 Entour below, or
- "Replacing the prism in a MAC 250 Krypton" on page 24.

REPLACING THE PRISM IN A MAC 250 ENTOUR

Danger! *Intense heat. Avoid contact by persons and materials. The exterior of the fixture can get very hot - up to 120° C (248° F). Disconnect the fixture from AC power and allow it to cool for at least 45 minutes before handling.*

Do not removing covers while the fixture is powered on as this exposes dangerous live electrical circuits, hot surfaces, and a lamp under high pressure.

- 1 Disconnect the fixture from AC power and allow it to cool.

- 2 Remove the top cover. The top and bottom cover look the same, but the top cover is found by checking if the text on the back of the head is oriented correctly (top) or not (bottom). Remove the top cover of the fixture head using a flathead screwdriver to loosen the four quarter-turn screws. The top and bottom cover look the same, but the top cover is found by checking if the text on the back of the head is oriented correctly (top) or not (bottom) as illustrated here.

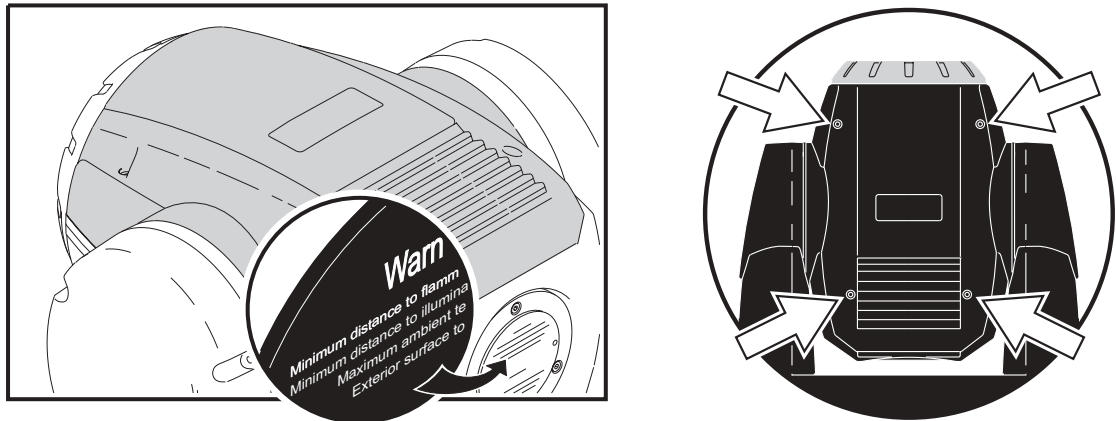

- 3 Using a flathead screwdriver, remove the two retaining plates (only one - at position A - is illustrated here) holding the prism module in place. Disconnect the cables (at positions marked B) from the PCBs on the prism module.

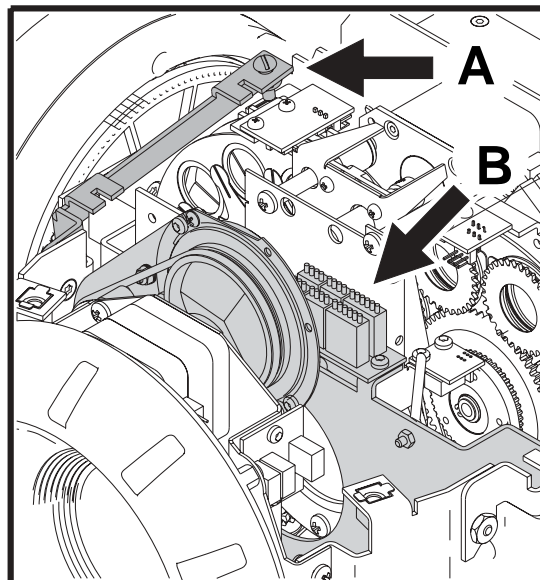

- 4 Lift the prism module out of the fixture.

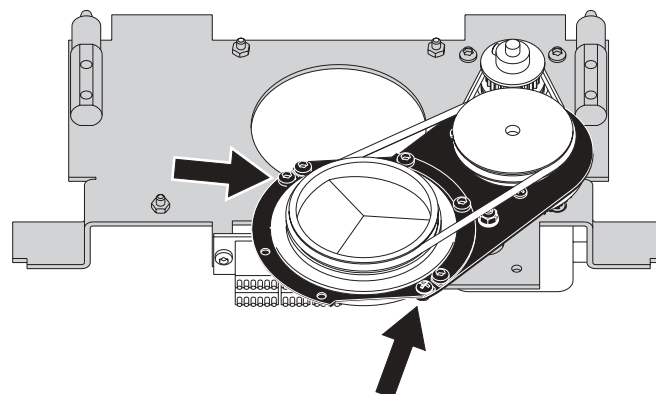

- Using a Philips screwdriver, remove the half-circle shaped plate that holds the prism into place (as indicated in this illustration).



- Remove the rubber belt to free the prism and replace it with a compatible rotating prism (contact your Martin dealer for a list of available prisms).
- Replace the rubber drive belt over the rotating prism and screw the half-circle shaped plate into place. The prism should be able to rotate freely.
- Reinsert the prism module into the fixture, reattach the leads (these are numbered) to the PCBs, and screw the retaining plates into place.
- Replace the top cover using a flathead screwdriver to tighten the four quarter-turn screws.
- Connect the fixture to AC power.

REPLACING THE PRISM IN A MAC 250 KRYPTON

Danger! *Intense heat. Avoid contact by persons and materials. The exterior of the fixture can get very hot - up to 120° C (248° F). Disconnect the fixture from AC power and allow it to cool for at least 45 minutes before handling.*

Do not removing covers while the fixture is powered on as this exposes dangerous live electrical circuits, hot surfaces, and a lamp under high pressure.

- Disconnect the fixture from AC power and allow it to cool.
- Remove the top cover. The top and bottom cover look the same, but the top cover is found by checking if the text on the back of the head is oriented correctly (top) or not (bottom). Remove the top cover of the fixture head using a flathead screwdriver to loosen the four quarter-turn screws. The top and bottom cover look the same, but the top cover is found by checking if the text on the back of the head is oriented correctly (top) or not (bottom) as illustrated here.

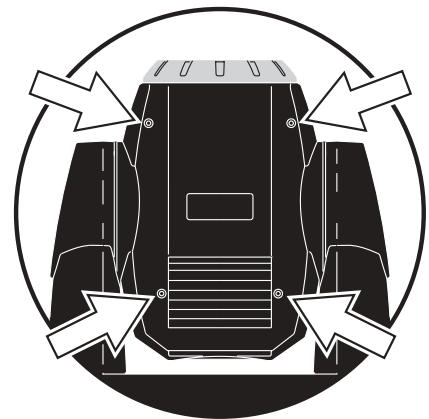
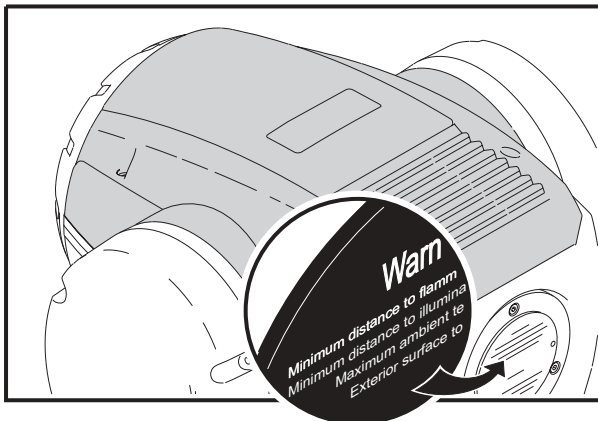

- 3 Using a flathead screwdriver, remove the two retaining plates (only one - at position A - is illustrated here) holding the prism module in place. Disconnect the cables (at positions marked B) from the PCBs on the prism module.

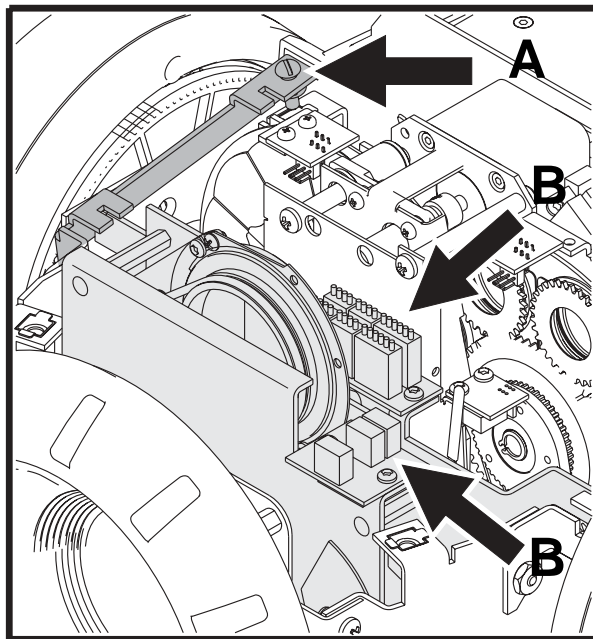

- 4 Lift the prism module out of the fixture.
- 5 Using a Philips screwdriver, remove the half-circle shaped plate that holds the prism into place (as indicated in this illustration).

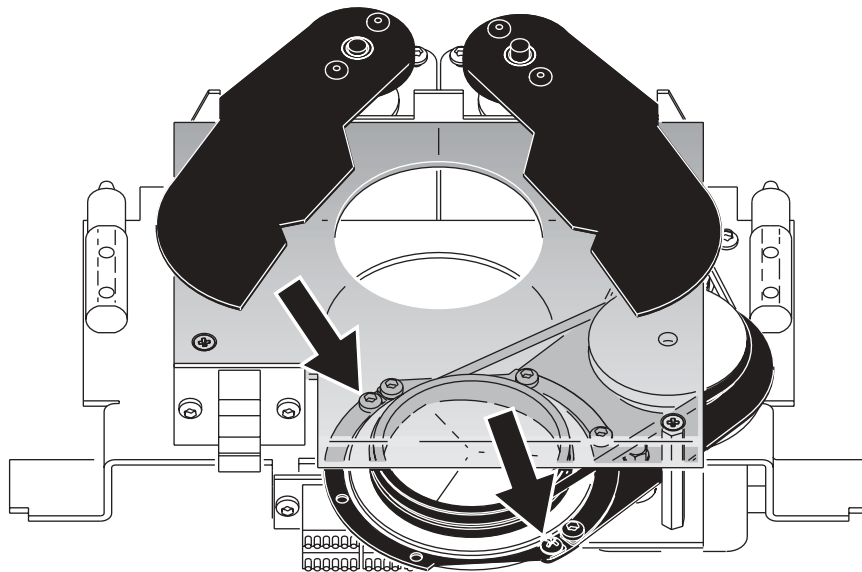

- 6 Remove the rubber belt to free the prism and replace it with a compatible rotating prism (contact your Martin dealer for a list of available prisms).



- 7 Replace the rubber drive belt over the rotating prism and screw the half-circle shaped plate into place. The prism should be able to rotate freely.
- 8 Reinsert the prism module into the fixture, reattach the leads (these are numbered) to the PCBs, and screw the retaining plates into place.
- 9 Replace the top cover using a flathead screwdriver to tighten the four quarter-turn screws.
- 10 Connect the fixture to AC power.

Mounting the optional 14° lens (MAC 250 Entour only)

The MAC 250 Entour is supplied with an optional 14° lens. Mounting optional 14 degree lens. to mount the lens:

- 1 Disconnect the fixture from AC power and allow it to cool.
- 2 Lock the head in top side up position. Remove the top cover of the fixture head using a flathead screwdriver to loosen the four quarter-turn screws. The top and bottom cover look the same, but the top cover is found by checking if the text on the back of the head is oriented correctly (top) or not (bottom) as illustrated here.

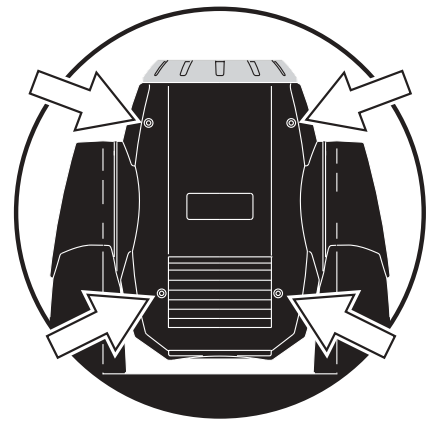
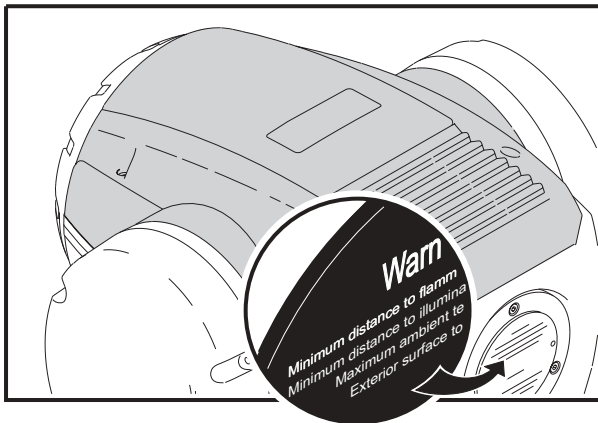

- 3 Locate the effect module and remove the wire connectors (located at position B). Using a flat head screwdriver, remove the screws (located at the positions marked A) and lift the tabs. Lift the effect module out of the fixture.

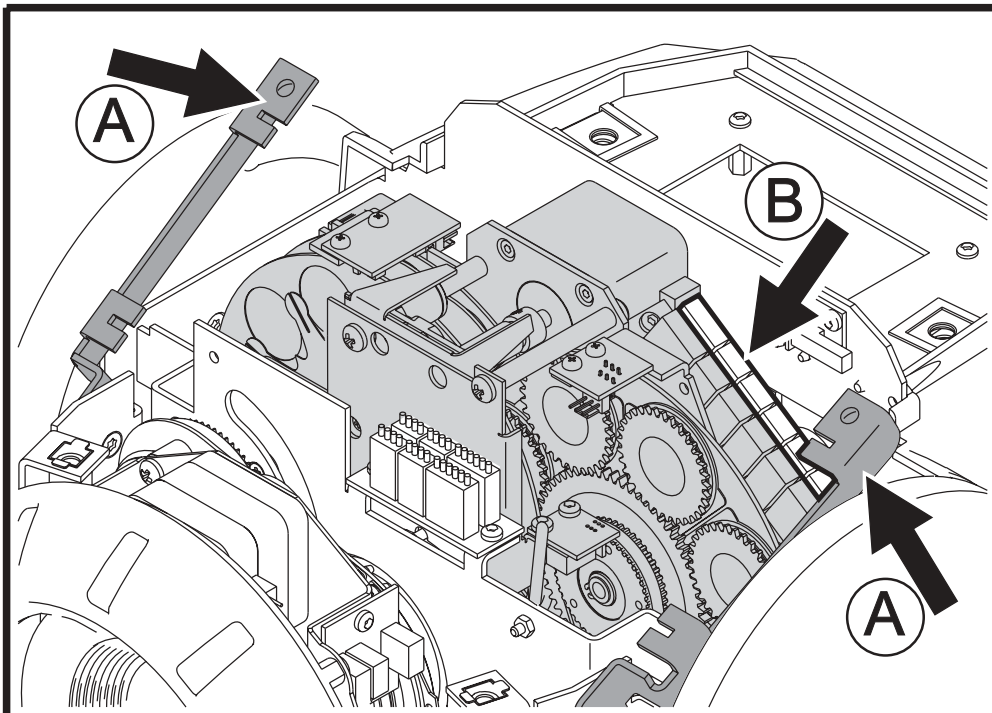

4 Remove the three Phillips screws and lift the plate off the effect module.

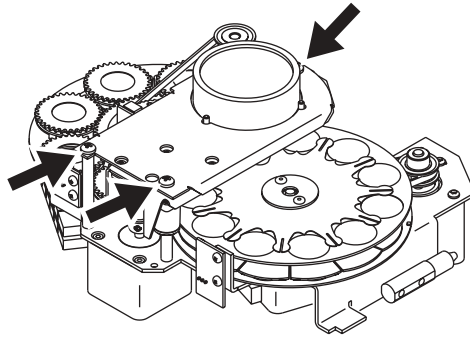

5 Remove the four Phillips screws.

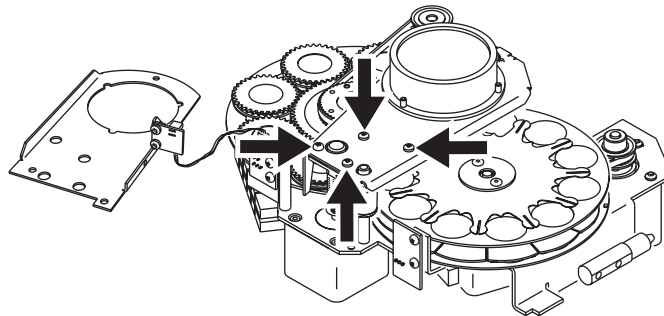

6 Lift the lens module plate off the effect module.

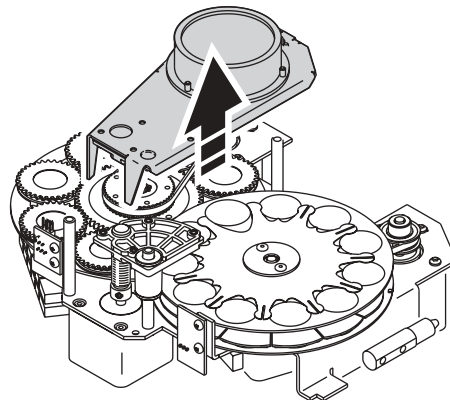

7 Remove the three Torx 10 screws holding the lens in place.

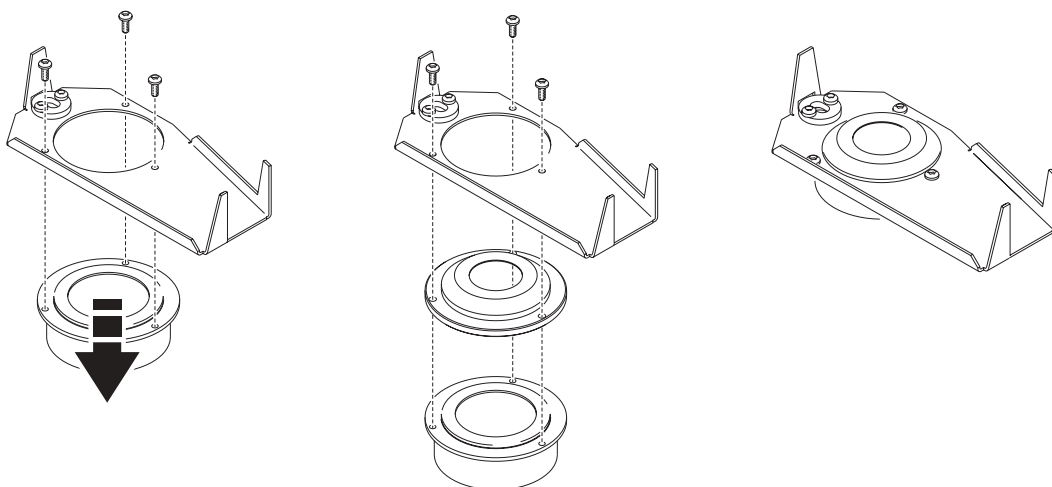

8 Place the 14° lens between the standard lens and the plate and replace the three Torx 10 screws.

9 Perform these steps in reverse, returning the components to their correct positions and replacing all the covers, before applying power to the fixture.

SERVICE

The MAC 250 Krypton/Entour requires regular maintenance to keep performing at their peak. Excessive dust, grease, and smoke fluid buildup degrades performance and causes overheating and damage that is not covered by the warranty. The maintenance schedule will depend on the application and should be discussed with your Martin distributor. Refer any service that is not described here to a professional technician.

Danger! *Intense heat. Avoid contact by persons and materials. The exterior of the fixture can get very hot - up to 120° C (248° F). Disconnect the fixture from AC power and allow the it to cool for at least 45 minutes before handling.*

Do not removing covers while the fixture is powered on as this exposes dangerous live electrical circuits, hot surfaces, and a lamp under high pressure.

Lamp replacement

Lamp life will vary; the rated life is an average figure that is based on the manufacturer's test cycle. For maximum lamp life, avoid excessive strikes and always allow the lamp to burn for at least 5 minutes before turning it off.

To reduce the risk of lamp explosion, which may damage the fixture, never exceed the lamp's rated life (3000 hours) by more than 25 percent.

Replace the lamp when:

- it strikes with difficulty or not at all, or is in any other way defective
- usage exceeds the manufacturer's "replace before" hours. See Table 5.

COMPATIBLE LAMPS

A Philips MSD 250/2 lamp is included installed. The MAC 250 Krypton/Entour lamp options are shown in the table below. *Installing any other lamp may damage the fixture.*

Lamp	Average life	Color Temp.
Osram HSD 250/78	3000 hr	7800K
Philips MSD 250/2	3000 hr	8500K
GE CSD 250/2	2000 hr	9000K

Table 5: Lamp comparison

INSTALLING A LAMP

Danger! *Intense heat. Avoid contact by persons and materials. The exterior of the fixture can get very hot - up to 120° C (248° F). When replacing the lamp, disconnect the fixture from AC*

power and allow it to cool for at least 45 minutes before proceeding. Wear safety goggles to protect your eyes.

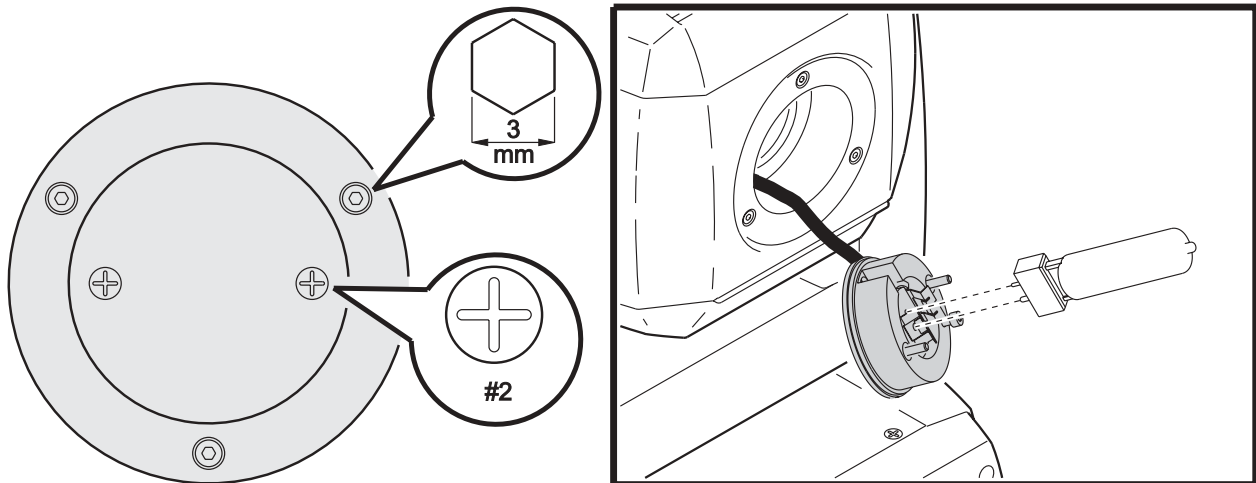

Figure 5: Lamp installation

- 1 Locate the lamp access cover at the back of the fixture head and remove the Phillips screws.
- 2 Pull out the lamp socket.
- 3 If changing the lamp, remove the old lamp from the socket.
- 4 Holding the new lamp by its ceramic base (do not touch the glass), align the small pin on the lamp with the small hole in the socket and insert the lamp squarely. Make sure that the 4 small projections on the base contact the face of the socket.
- 5 Clean the glass bulb with the cloth supplied with the lamp, particularly if your fingers touched the glass. A clean, lint-free cloth wetted with alcohol may also be used.
- 6 Insert the lamp into the fixture with as little twist in the lamp wires as possible.
- 7 Align the screw holes and fasten the lamp access plate with 2 screws.
- 8 If replacing the lamp, reset the lamp hour and lamp strike counters as described on page 12.
- 9 Strike the lamp (after setup is complete) and adjust it for optimum performance by turning the 3 adjustment screws one at a time until the brightest part of the beam is centered.
- 10 Adjust the lamp position if necessary by turning the 3 lamp adjustment screws to the middle of their range using a 3 mm Allen wrench.

Cleaning

OPTICAL COMPONENTS

Use care when cleaning optical components. The surface on dichroic filters is achieved by means of special multi-layer coatings and even small scratches may be visible. Residues from cleaning fluids can bake onto components and ruin them.

- 1 Allow the components to cool completely.
- 2 Wash dirty lenses and filters with isopropyl alcohol. A generous amount of regular glass cleaner may also be used, but no residues may remain.
- 3 Rinse with distilled water. Mixing the water with a small amount of wetting agent such as Kodak Photoflo will help prevent streaking and spotting.
- 4 Dry with a clean, soft and lint-free cloth or blow dry with compressed air.

FAN

To maintain adequate cooling it is important that the fan be cleaned regularly. It can be cleaned with a soft brush, vacuum, or compressed air.

Lubrication

The MAC 250 Krypton/Entour does not require lubrication under normal circumstances. The slides and spindle for the focus lens car are lubricated with a long-lasting Teflon-based lubricant that can be reapplied by a Martin service partner in the unlikely event that this should be necessary.

Replacing fuses

MAIN FUSE

The main fuse holder is built in to the mains input socket. *Never replace the fuse with one of a different rating!*

- 1 Unplug the mains cable from the input socket.
- 2 Pry open the fuse holder and remove the fuse.
- 3 Replace the fuse with one of the same type and rating. The fuse rating is listed on serial number label.
- 4 Close the fuse holder and replace the mains cable.

POWER SUPPLY FUSES

There are two fuses for the low-voltage power supplies located on the printed circuit board. If one or more of the green LEDs on the PCB does not light, one of these fuses may be blown. If all three LEDs are lit, the low-voltage power supplies are functioning correctly.

Have the fixture serviced by a Martin service technician if the problem persists.

- 1 Disconnect the fixture from AC power.
- 2 Remove the left-side yoke cover (when looking at the head in the text in the upright position from the back as indicated in the illustration) to access the PCB.

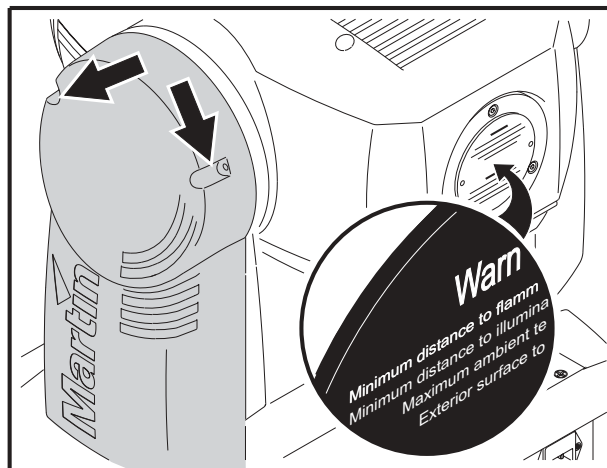

- 3 Carefully remove and check the two fuses located in the bottom of the PCB (see "Circuit board connections" on page 45). Replace as necessary with fuses of the same size and rating (see page 46).
- 4 Re-attach the yoke cover.

Updating software

The latest MAC 250 Krypton/Entour firmware is available from the support area of the Martin web site at www.martin.dk. It can be installed via the serial data link using a supported Martin uploader such as the MP-2, or via a LightJockey 4064 ISA DMX interface.

Note: Intermediate control systems such as the Martin Lighting Director (MLD) and the Martin Matrix must be bypassed when updating fixture software via the DMX link. These systems do not relay the update code correctly because it is not a DMX-compliant signal.

NORMAL UPDATE

To update fixture software, connect an upload device to the fixture just like a DMX controller and perform a DMX mode upload as described in the uploader's documentation. There is no need to isolate the MAC 250 Krypton/Entours from other types of fixtures on the serial link.

When the upload is completed (and when booting up) the MAC 250 Krypton/Entour performs a check-sum test of the flash memory and then resets. If the firmware is corrupted a check-sum error (CSEr) occurs. A few seconds later the fixture displays `UPLD` and is ready for a new DMX-mode upload.

In the unlikely event that a software upload is interrupted, the fixture must be powered off for at least 10 seconds to force the check-sum test. You can repeat the DMX-mode upload as soon as `UPLD` is displayed.

BOOT SECTOR UPDATE

If the normal update procedure fails or the software update notes call for a boot-sector update, install new software as follows.

- 1 Disconnect the fixture from AC power.
- 2 Remove the left-side yoke cover (when looking at the head in the text in the upright position from the back as indicated in the illustration) to access the PCB.

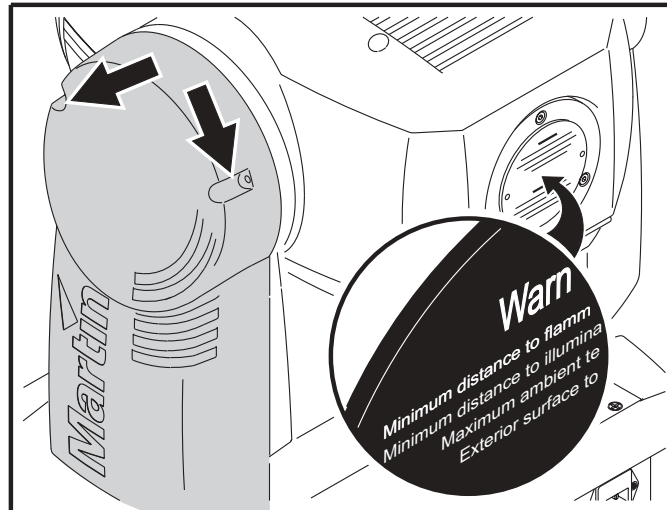

- 3 The boot sector jumper is located next to the plug for the control panel data cable. Move the jumper to the Init setting. Verify that the Flash Write jumper is in the Enable position. See the diagram in "Circuit board connections" on page 45.
- 4 Apply power and perform a boot-mode upload as described in the uploader manual.
- 5 Disconnect the fixture from AC power. Move the jumper back to the Lock setting.
- 6 Re-attach the yoke cover.

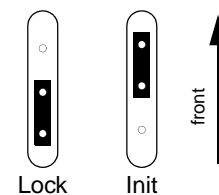

DMX PROTOCOL

This chapter contains:

- “MAC 250 Krypton DMX protocol” on page 33
- “MAC 250 Entour DMX protocol” on page 36

MAC 250 Krypton DMX protocol

16 Bt (16 Bit Mode)	16 Ex (16 Bit Extended)	Value	Percent	Function
	1	0 - 19 20 - 49 50 - 72 73 - 79 80 - 99 100 - 119 120 - 127 128 - 147 148 - 167 168 - 187 188 - 190 191 - 193 194 - 196 197 - 199 200 - 202 203 - 207 208 - 217 218 - 227 228 - 237 238 - 247 248 - 255	0 - 7 8 - 19 20 - 28 29 - 31 31 - 39 39 - 47 47 - 50 50 - 58 58 - 65 66 - 73 74 - 75 75 - 76 76 - 77 77 - 78 78 - 79 80 - 81 82 - 85 85 - 89 89 - 93 93 - 97 97 - 100	Shutter, Strobe, Reset, Lamp On/Off Shutter closed Shutter open Strobe, fast → slow Shutter open Opening pulse, fast → slow Closing pulse, fast → slow Shutter open Random strobe, fast Random strobe, medium Random strobe, slow Shutter open Random opening pulse, fast Random opening pulse, slow Random closing pulse, fast Random closing pulse, slow Shutter open Reset fixture Shutter open Lamp on Shutter open Lamp off
	2	0 - 255	0 - 100	Dimmer Closed → open
	3	0-255	0-100	Dimmer Fine (Lowest Significant Byte) Closed → open
	4	0 11 22 33 44 55 66 77 88 99 110 121 132 143 156 - 159 160 - 163 164 - 167 168 - 171 172 - 175 176 - 179 180 - 183 184 - 187 188 - 191 192 - 195 196 - 199 200 - 203 204 - 207 208 - 226 227 - 245 246 - 248 249 - 251 252 - 255	0 4 9 13 17 22 26 30 35 39 43 47 52 56 61 - 63 63 - 64 64 - 65 66 - 67 67 - 68 69 - 70 70 - 72 72 - 73 74 - 75 75 - 76 77 - 78 78 - 79 80 - 81 82 - 88 89 - 96 96 - 97 98 - 98 99 - 100	Color Continuous Scroll: full color positions: White CTC Yellow 603 Blue 104 Pink 312 Green 206 Blue 108 Red 301 Magenta 507 Blue 101 Orange 306 Dark green Purple 502 White Stepped Scroll White CTC Yellow 603 Blue 104 Pink 312 Green 206 Blue 108 Red 301 Magenta 507 Blue 101 Orange 306 Dark green Purple 502 Continuous Rotation CW, fast → slow CCW, slow → fast Random color Fast Medium Slow
	5	0 - 255	0 - 100	Color (Lowest Significant Byte)

¹If DMX Reset is disabled in the menu, a reset command can only be executed if the CTC filter is selected, the prism is on (not rotating) and the open gobo is selected.

A 5 second delay can be given to the reset command from the fixture menu under, dRES.

²If DMX Lamp Off is disabled in the menu, a lamp off command can only be executed if the CTC filter is selected, the prism is on (not rotating) and the open gobo is selected.

4	6	0 - 4	0 - 2	Rotating Gobo selection and shake
		5 - 10	2 - 4	Indexing: set position on channel 5 in 16 bt mode or channel 6 in 16 Ex mode
		11 - 15	4 - 6	Open gobo
		16 - 20	6 - 8	Gobo 1
		21 - 25	8 - 10	Gobo 2
		26 - 30	10 - 12	Gobo 3
		31 - 35	12 - 14	Gobo 4
		36 - 42	14 - 16	Gobo 5
				Gobo 6
				Gobo 7
		43 - 50	17 - 20	Rotation: set rotation speed on channel 5 in 16 bt mode or channel 6 in 16 Ex mode
		51 - 58	20 - 23	Open gobo
		59 - 65	23 - 26	Gobo 1
		66 - 73	26 - 29	Gobo 2
		74 - 81	29 - 32	Gobo 3
		82 - 89	32 - 35	Gobo 4
		90 - 96	35 - 38	Gobo 5
		97 - 104	38 - 41	Gobo 6
				Gobo 7
				Rotation with shake, slow → fast: set rotation speed on channel 5 in 16 bt mode or channel 6 in 16 Ex mode
		105 - 119	41 - 46	Gobo 7, Shake slow → fast
		120 - 134	47 - 52	Gobo 6, Shake slow → fast
		135 - 149	53 - 58	Gobo 5, Shake slow → fast
		150 - 164	59 - 64	Gobo 4, Shake slow → fast
		165 - 179	65 - 70	Gobo 3, Shake slow → fast
		180 - 194	70 - 76	Gobo 2, Shake slow → fast
		195 - 209	76 - 82	Gobo 1, Shake slow → fast
				Continuous scroll
		210 - 232	82 - 91	CW slow → fast
		233 - 255	91 - 100	CCW fast → slow
5	7	0 - 255	0 - 100	Gobo rotation (active when you select gobo on channel 4 in 16 bt mode or channel 5 in 16 Ex mode)
				Index position 0 - 395
		0 - 2	0 - 1	Continuous rotation (direction and speed)
		3 - 127	1 - 50	No rotation
		128 - 252	50 - 98	CW, slow → fast
		253 - 255	99 - 100	CCW, fast → slow
				No rotation
6	8	0 - 255	0 - 100	Gobo Rotation ((Lowest Significant Byte)
7	9	0 - 255	0 - 100	Focus
				Infinity → 2 meters
	10	0 - 255	0 - 100	Focus (Lowest Significant Byte)
8	11	0 - 19	0 - 7	Prism
		20 - 79	8 - 31	Prism off
		80 - 89	31 - 35	Rotating prism, CCW fast à slow
		90 - 149	35 - 58	No rotation
		150 - 215	59 - 84	Rotating prism, CW slow à fast
				Prism off
				Prism/Gobo Macros
				Macro 1
				Macro 2
				Macro 3
		Macro 4		
		Macro 5		
		Macro 6		
		Macro 7		
		Macro 8		
9	12	0 - 255	0 - 100	Pan
				Left → right (128 = neutral)
10	13	0 - 255	0 - 100	Pan Fine (Lowest Significant Byte)
				Left → right
11	14	0 - 255	0 - 100	Tilt
				Left → right (128 = neutral)
12	15	0 - 255	0 - 100	Tilt Fine (Lowest Significant Byte)
				Left → right

13	16	0 - 2 3 - 245 246 - 248 249 - 251 252 - 255	0 - 1 1 - 96 96 - 97 98 - 98 99 - 100	Pan/Tilt Speed Tracking Fast → slow Tracking, PTSP NORM (menu override) Tracking, PTSP FAST (menu override) Blackout while moving
14	17	0 - 2 3 - 245 246 - 251 252 - 255 0 - 2 3 - 245 246 - 248 249 - 251 252 - 255 0 - 245 246 - 248 249 - 251 252 - 255 0 - 2 3 - 245 246 - 251 252 - 255 0 - 251 252 - 255	0 - 1 1 - 96 96 - 98 99 - 100 0 - 1 1 - 96 96 - 97 98 - 98 99 - 100 0 - 96 96 - 97 98 - 98 99 - 100 0 - 1 1 - 96 96 - 98 99 - 100 0 - 98 99 - 100	Effects Speed Dimmer, focus Tracking mode Fast → slow Tracking Maximum speed Color Tracking mode Speed, fast → slow Tracking, SCUT OFF (control menu override) Tracking, SCUT ON (control menu override) Blackout while moving Gobo selection Normal (no blackout) Normal, SCUT OFF (control menu override) Normal, SCUT ON (control menu override) Blackout while moving Indexed gobo rotation (only if gobo type = indexed) Tracking mode Fast → slow Tracking Blackout while moving Prism Normal (no blackout) Blackout while moving

MAC 250 Entour DMX protocol

16 Bt (16 Bit Mode)	16 Ex (16 Bit Extended)	Value	Percent	Function
	1	0 - 19 20 - 49 50 - 72 73 - 79 80 - 99 100 - 119 120 - 127 128 - 147 148 - 167 168 - 187 188 - 190 191 - 193 194 - 196 197 - 199 200 - 202 203 - 207 208 - 217 218 - 227 228 - 237 238 - 247 248 - 255	0 - 7 8 - 19 20 - 28 29 - 31 31 - 39 39 - 47 47 - 50 50 - 58 58 - 65 66 - 73 74 - 75 75 - 76 76 - 77 77 - 78 78 - 79 80 - 81 82 - 85 85 - 89 89 - 93 93 - 97 97 - 100	Shutter, Strobe, Reset, Lamp On/Off Shutter closed Shutter open Strobe, fast → slow Shutter open Opening pulse, fast → slow Closing pulse, fast → slow Shutter open Random strobe, fast Random strobe, medium Random strobe, slow Shutter open Random opening pulse, fast Random opening pulse, slow Random closing pulse, fast Random closing pulse, slow Shutter open Reset fixture Shutter open Lamp on Shutter open Lamp off
	2	0 - 255	0 - 100	Dimmer Closed → open
	3	0-255	0-100	Dimmer Fine (Lowest Significant Byte) Closed → open
	4	0 11 22 33 44 55 66 77 88 99 110 121 132 143 156 - 159 160 - 163 164 - 167 168 - 171 172 - 175 176 - 179 180 - 183 184 - 187 188 - 191 192 - 195 196 - 199 200 - 203 204 - 207 208 - 226 227 - 245 246 - 248 249 - 251 252 - 255	0 4 9 13 17 22 26 30 35 39 43 47 52 56 61 - 63 63 - 64 64 - 65 66 - 67 67 - 68 69 - 70 70 - 72 72 - 73 74 - 75 75 - 76 77 - 78 78 - 79 80 - 81 82 - 88 89 - 96 96 - 97 98 - 98 99 - 100	Color Continuous Scroll: full color positions: White CTC Yellow 603 Blue 104 Pink 312 Green 206 Blue 108 Red 301 Magenta 507 Blue 101 Orange 306 Dark green Purple 502 White Stepped Scroll White CTC Yellow 603 Blue 104 Pink 312 Green 206 Blue 108 Red 301 Magenta 507 Blue 101 Orange 306 Dark green Purple 502 Continuous Rotation CW, fast → slow CCW, slow → fast Random color Fast Medium Slow
	5	0 - 255	0 - 100	Color (Lowest Significant Byte)

4	6	0 - 4	0 - 2	Rotating Gobo selection and shake
		5 - 10	2 - 4	Indexing: set position on channel 5 in 16 bt mode or channel 6 in 16 Ex mode
		11 - 15	4 - 6	Open gobo
		16 - 20	6 - 8	Gobo 1
		21 - 25	8 - 10	Gobo 2
		26 - 30	10 - 12	Gobo 3
		31 - 35	12 - 14	Gobo 4
		36 - 42	14 - 16	Gobo 5
				Gobo 6
				Gobo 7
		43 - 50	17 - 20	Rotation: set rotation speed on channel 5 in 16 bt mode or channel 6 in 16 Ex mode
		51 - 58	20 - 23	Open gobo
		59 - 65	23 - 26	Gobo 1
		66 - 73	26 - 29	Gobo 2
		74 - 81	29 - 32	Gobo 3
		82 - 89	32 - 35	Gobo 4
		90 - 96	35 - 38	Gobo 5
		97 - 104	38 - 41	Gobo 6
				Gobo 7
		105 - 119	41 - 46	Rotation with shake, slow → fast: set rotation speed on channel 5 in 16 bt mode or channel 6 in 16 Ex mode
		120 - 134	47 - 52	Gobo 7, Shake slow → fast
		135 - 149	53 - 58	Gobo 6, Shake slow → fast
		150 - 164	59 - 64	Gobo 5, Shake slow → fast
		165 - 179	65 - 70	Gobo 4, Shake slow → fast
		180 - 194	70 - 76	Gobo 3, Shake slow → fast
		195 - 209	76 - 82	Gobo 2, Shake slow → fast
				Gobo 1, Shake slow → fast
		210 - 232	82 - 91	Continuous scroll
		233 - 255	91 - 100	CW slow → fast
				CCW fast → slow
5	7	0 - 255	0 - 100	Gobo rotation (active when you select gobo on channel 4 in 16 bt mode or channel 5 in 16 Ex mode)
				Index position 0 - 395
		0 - 2	0 - 1	Continuous rotation (direction and speed)
		3 - 127	1 - 50	No rotation
		128 - 252	50 - 98	CW, slow → fast
		253 - 255	99 - 100	CCW, fast → slow
				No rotation
6	8	0 - 255	0 - 100	Gobo Rotation ((Lowest Significant Byte)
7	9	0 - 7	0 - 3	Gobo Wheel 2 (static). Selection and Shake
		8 - 15	3 - 6	Open gobo
		16 - 23	6 - 9	Gobo 1
		24 - 31	9 - 12	Gobo 2
		32 - 39	13 - 15	Gobo 3
		40 - 47	16 - 18	Gobo 4
		48 - 55	19 - 22	Gobo 5
		56 - 63	22 - 25	Gobo 6
		64 - 71	25 - 28	Gobo 7
		72 - 79	28 - 31	Gobo 8
		80 - 87	31 - 34	Gobo 9
		88 - 95	35 - 37	Gobo 10
				Open
		96 - 105	38 - 41	Gobo Shake
		106 - 115	42 - 45	Gobo 10 - Shake, slow → fast
		116 - 125	45 - 49	Gobo 9 - Shake, slow → fast
		126 - 135	49 - 53	Gobo 8 - Shake, slow → fast
		136 - 145	53 - 56	Gobo 7 - Shake, slow → fast
		146 - 155	57 - 60	Gobo 6 - Shake, slow → fast
		156 - 165	61 - 65	Gobo 5 - Shake, slow → fast
		166 - 175	65 - 69	Gobo 4 - Shake, slow → fast
		176 - 185	69 - 73	Gobo 3 - Shake, slow → fast
		186 - 195	73 - 76	Gobo 2 - Shake, slow → fast
		196 - 205	77 - 80	Gobo 1 - Shake, slow → fast
				Open Gobo - Shake, slow → fast
		206 - 230	81 - 90	Continuous Rotation
		231 - 255	91 - 100	CW slow → fast
				CCW fast → slow

8	10	0 - 255	0 - 100	Focus Infinity → 2 meters
	11	0 - 255	0 - 100	Focus (Lowest Significant Byte)
9	12	0 - 19 20 - 79 80 - 89 90 - 149 150 - 215	0 - 7 8 - 31 31 - 35 35 - 58 59 - 84	Prism Prism off Rotating prism, CCW fast à slow No rotation Rotating prism, CW slow à fast Prism off Prism/Gobo Macros Macro 1 Macro 2 Macro 3 Macro 4 Macro 5 Macro 6 Macro 7 Macro 8
10	13	0 - 255	0 - 100	Pan Left → right (128 = neutral)
11	14	0 - 255	0 - 100	Pan Fine (Lowest Significant Byte) Left → right
12	15	0 - 255	0 - 100	Tilt Left → right (128 = neutral)
13	16	0 - 255	0 - 100	Tilt Fine (Lowest Significant Byte) Left → right
14	17	0 - 2 3 - 245 246 - 248 249 - 251 252 - 255	0 - 1 1 - 96 96 - 97 98 - 98 99 - 100	Pan/Tilt Speed Tracking Fast → slow Tracking, PTSP NORM (menu override) Tracking, PTSP FAST (menu override) Blackout while moving
15	18	0 - 2 3 - 245 246 - 251 252 - 255	0 - 1 1 - 96 96 - 98 99 - 100	Effects Speed Dimmer, focus Tracking mode Fast → slow Tracking Maximum speed Color Tracking mode Speed, fast → slow Tracking, SCUT OFF (control menu override) Tracking, SCUT ON (control menu override) Blackout while moving Gobo selection Normal (no blackout) Normal, SCUT OFF (control menu override) Normal, SCUT ON (control menu override) Blackout while moving Indexed gobo rotation (only if gobo type = indexed) Tracking mode Fast à slow Tracking Blackout while moving Prism Normal (no blackout) Blackout while moving

CONTROL MENU

Options displayed in bold represent the default settings.

Menu	Item	Options	Notes (Default settings in bold print)
Addr	-	1 - 512	DMX address
PSET		16BT	16 Bit
		16EX	16 Bit extended
PATI	SWAP	ON	Map DMX pan control to tilt channel and vice versa.
		OFF	Normal pan and tilt control
	PINV	ON	Reverse DMX pan control, right → left
		OFF	Normal pan control, left → right
	TINV	ON	Reverse DMX tilt control, down → up
		OFF	Normal tilt control, up → down
PTSP		NORM	Default pan/tilt speed
		FAST	Maximum pan/tilt speed (position may be less precise)
		SLOW	Minimum pan/tilt speed
PERS	dISP	ON	Display remains on
		2 MN	Display extinguishes 2 minutes after last key press
		10MN	Display extinguishes 10 minutes after last key press
	dINT	AUTO	Automatic display dimming
		10 - 100	Set display intensity manually
	dLOF	ON	Enable DMX lamp off command
		OFF	Disable DMX lamp off command
	dRES	ON	Enable DMX reset command
		OFF	Disable DMX reset command
		5 SEC	Reset from Controller
	ALON	ON	Lamp strikes automatically within 90 seconds of power on
		OFF	No automatic lamp strike
		dMX	Lamp strikes if DMX is present, douses 15 mins. after it's missing
	SCUT	ON	Effect wheels turn shortest distance
		OFF	Effect wheels do not cross open position
dICU	DIM1	0-100%	
	DIM2	Tungsten	
dFSE	FACT	LOAD	Return all personality settings (not calibrations) to factory defaults

INFO	TIME / L HR	RSET	Hours of operation since counter reset. To reset, display counter and press [up] for 5 seconds.
		TOTL	Total hours of operation with lamp on since fabricated
		RSET	Lamp hours since counter reset. To reset, display counter and press [up] for 5 seconds.
	TIME / L ST	TOTL	Total number of lamp strikes since fabricated
		RSET	Number of lamp strikes since counter reset. To reset, display counter and press [up] for 5 seconds.
	VER	X . X	CPU firmware version
	TEMP	HEAD	Head temperature
		BASE	Base Temperature
dMXL	-	RATE	DMX packets per second
		qUAL	Percentage of data received without errors
		STCO	Decimal value of the DMX start code.
		SHUT . . EFSP	DMX value (from 0 → 255) received for each channel.
		SHUT	Shutter value
		DIM	Dimmer value
		COL	Color wheel value
		GOBO	Fixed gobo value
		ROGO	Rotating gobo value
		FOC	Focus value
		PRIS	Prism value
		PANC	Coarse pan value
		PANF	Fine pan value
		TILC	Coarse tilt value
		TILF	Fine tilt value
		PTSP	Pan/tilt speed value
		EFSP	Effect speed value

MAN	RST	-	Reset fixture	
	L ON	-	Lamp on	
	LoFF	-	Lamp off	
	SHUT	OPEN		Open shutter
		CLOS		Close shutter
		STRF		Fast strobe
		STRM		Medium strobe
		STRS		Slow strobe
	dIM	0-255	Dimmer	
	COL	OPEN	Color wheel in open position.	
	12	C1-C12		Color wheel positions 1 → 12.
		CW F		Clockwise rotation - fast
		CCWF		Counter-clockwise rotation - fast
		CW M		Clockwise rotation - medium
		CCWM		Counter-clockwise rotation - medium
		CW S		Clockwise rotation - slow
		CCWS		Counter-clockwise rotation - slow
		RNdF		Random color - fast
		RNdM		Random color - medium
		RNdS		Random color - slow
	gObO	OPEN		Gobo wheel in open position
		g1 l-g7 l		Indexed gobos 1-7
		g1 R-g7 R		Rotating gobos 1-7
		g1RS-g7RS		Rotating gobo shake 1-7
		CW F		Clockwise rotation, fast
		CCWF		Counter-clockwise rotation, fast
		CW M		Clockwise rotation, medium
CCWM			Counter-clockwise rotation, medium	
CW S			Clockwise rotation, slow	
CCWS			Counter-clockwise rotation - slow	
I/S	0-255	Clockwise rotation of gobo wheel. Slow - fast.		

MAN (cont.)	PRIS	ON	Prism in
		OFF	Prism out
		CWF	Clockwise rotation - fast
		CCWF	Counter-clockwise rotation - fast
		CWM	Clockwise rotation - medium
		CCWM	Counter-clockwise rotation - medium
		CWS	Clockwise rotation - slow
		CCWS	Counter-clockwise rotation - slow
	FOC	0-255	Focus, Infinity-Near
	PAN	0-255	Pan, Left-Right
TILT	0-255	Tilt, Up-Down	
TSEQ	-	RUN	Run a general test of all effects
UTIL (Press and hold Enter more than 3 sec. to access)	FEbA	ON	Magnetic sensors monitor the positions of the color wheel, gobo wheel, and rotating gobos. If they detect an error, the shutter closes while the effect resets.
		OFF	Effect feedback disabled.
	EFFb	ON	Enable on the fly reset of magnetically indexed effects
		OFF	Disable on the fly reset of magnetically indexed effects
	Adj	-	Not implemented
	CAL	-	Not implemented
	dFOF	SURE	Return all offsets to the default settings
	PCbT	Led	PCB test for service use only.
UPLd	SURE	Manually set fixture to software update mode	

ERROR MESSAGES

Display readout	Appears if...	What to do
MERR (Memory error)	...the EEPROM memory cannot be read.	<ul style="list-style-type: none"> • Contact service technician.
****	... there is no communication between the control panel and motherboard. This appears briefly when switching on the fixture.	<ul style="list-style-type: none"> • Check fuses. • Check cable between control panel and motherboard. • Reinstall software. • Contact service technician.
COER (Color wheel time-out) RGER (Rot. gobo time-out) FGER (Fixed gobo time-out) GOER (Gobo index time out)	...the magnetic-indexing circuit malfunctions (e.g. sensor defective or magnet missing).	<ul style="list-style-type: none"> • After the time-out, the effect in question stops in a random position. • Contact service technician.
L1ER	...the software don't detect any pulses from the light sensor for a specific period of time.	<ul style="list-style-type: none"> • Ensure that the light sensor cable is mounted correctly on the PL54 connector, or alternatively the light sensors might be defective.
LERR	...the lamp cannot be struck.	<ul style="list-style-type: none"> • Replace the lamp
shERthere is a short circuit and the lamp is struck without a command.	<ul style="list-style-type: none"> • Contact service technician.
bTER	...the temperature in the base is too high	<ul style="list-style-type: none"> • Ensure that the fans are clear and functioning and that the ambient temperature does not exceed 40° C (104° F) • Contact service technician if the problem persists.
PAER	...if there is a pan error and the sensor cannot find the pan index point	<ul style="list-style-type: none"> • After the time-out, the fixture stops in a random position. • Contact service technician.
TIER	...if there is a tilt error and the sensor cannot find the pan index point	<ul style="list-style-type: none"> • After the time-out, the fixture stops in a random position. • Contact service technician.
dRER	...if there is a drive current error.	<ul style="list-style-type: none"> • Contact service technician.
dPER	...if there is a display programming error.	<ul style="list-style-type: none"> • Contact service technician.

Table 6: Error messages

TROUBLESHOOTING

Problem	Probable cause(s)	Remedy
One or more of the fixtures is completely dead.	No power to fixture.	<ul style="list-style-type: none"> • Check that power is switched on and cables are plugged in.
	Primary fuse blown.	<ul style="list-style-type: none"> • Replace fuse.
	Secondary fuse(s) blown (located on PCB inside base).	<ul style="list-style-type: none"> • Check fuses on PCB and replace.
Fixtures reset correctly but all respond erratically or not at all to the controller.	The controller is not connected.	<ul style="list-style-type: none"> • Connect controller.
	XLR pin-out of the controller does not match pin-out of the first fixture on the link (i.e. signal is reversed).	<ul style="list-style-type: none"> • Install a phase-reversing cable between the controller and the first fixture on the link.
Fixtures reset correctly but some respond erratically or not at all to the controller.	Poor data quality	<ul style="list-style-type: none"> • Check data quality (page 13). If much under 100 percent, the problem may be a bad data link connection, poor quality or broken cabling, missing termination, or a defective fixture disturbing the link.
	Bad data link connection	<ul style="list-style-type: none"> • Inspect connections and cables. Correct poor connections. Repair or replace damaged cables.
	Data link not terminated with 120Ω termination plug.	<ul style="list-style-type: none"> • Insert termination plug in output jack of the last fixture on the link.
	Incorrect addressing of the fixtures.	<ul style="list-style-type: none"> • Check address setting.
	One of the fixtures is defective and disturbs data transmission on the link.	<ul style="list-style-type: none"> • Bypass one fixture at a time until normal operation is regained: unplug both connectors and connect them directly together. • Have the defective fixture serviced by a qualified technician.
	XLR pin-out on fixtures does not match (pins 2 and 3 reversed).	<ul style="list-style-type: none"> • Install a phase-reversing cable between the fixtures or swap pins 2 and 3 in the fixture that behaves erratically.
Shutter closes suddenly.	The color wheel, gobo wheel, or a gobo has lost its index position and the fixture is resetting the effect.	<ul style="list-style-type: none"> • Contact Martin technician for service if the problem persists.
No light and “LERR” error message displayed.	The power supply settings do not match local AC voltage and frequency.	<ul style="list-style-type: none"> • Disconnect fixture. Check settings (“AC power” on page 7) and correct if necessary.
	Lamp missing or blown	<ul style="list-style-type: none"> • Disconnect fixture and replace lamp.
Lamp cuts out intermittently.	Fixture is too hot.	<ul style="list-style-type: none"> • Allow fixture to cool. • Clean fan. • Make sure air vents at control panel and front lens are not blocked. • Turn up the air conditioning.
	The power supply settings do not match local AC voltage and frequency.	<ul style="list-style-type: none"> • Disconnect fixture. Check settings (“AC power” on page 7) and correct if necessary.

Table 7: Troubleshooting

CIRCUIT BOARD CONNECTIONS

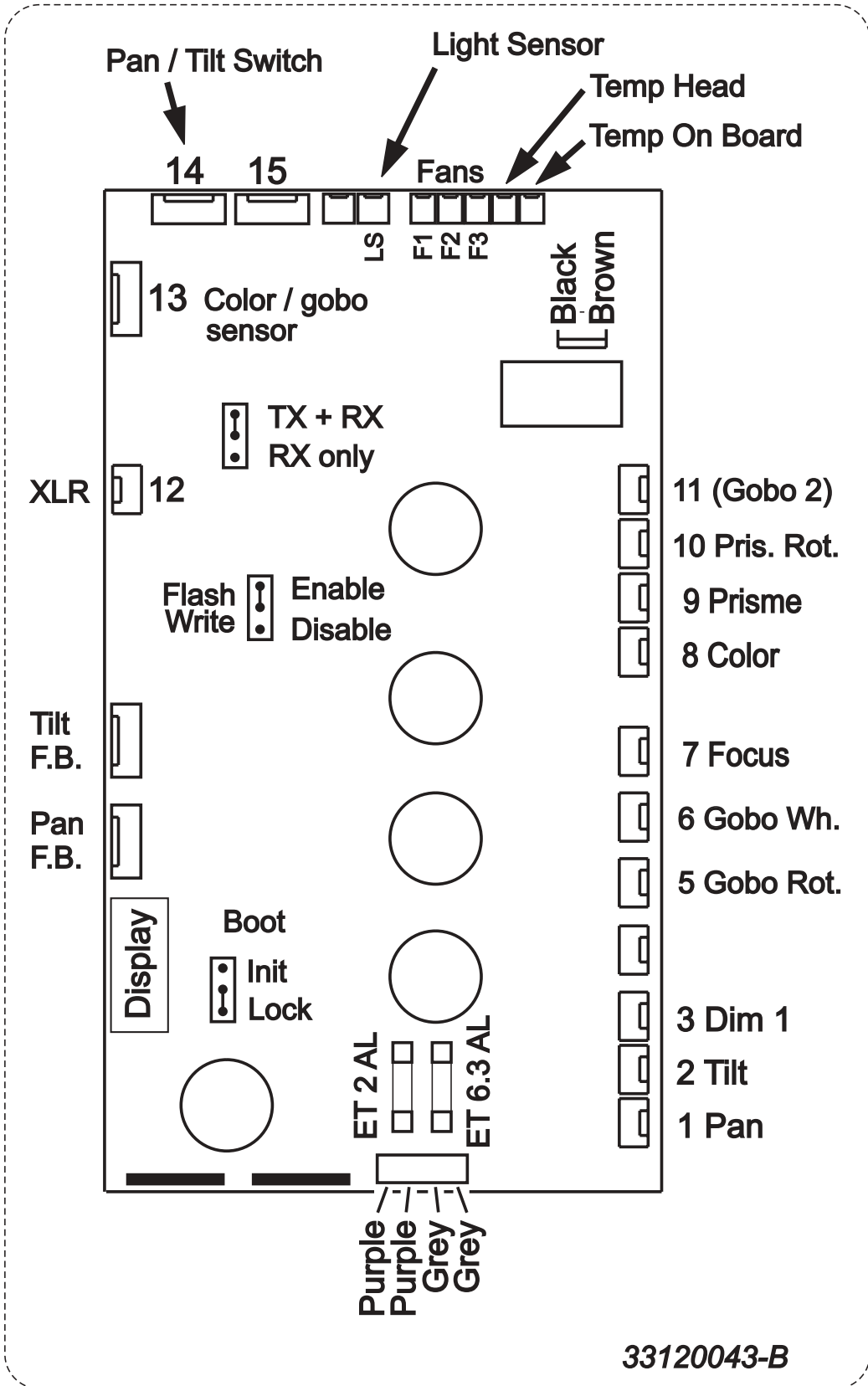

33120043-B

SPECIFICATIONS - MAC 250 KRYPTON

PHYSICAL

Base length	375 mm (14.8 in)
Base width	315 mm (12.4 in)
Yoke width	393 mm (15.5 in)
Height	538 mm (21.2 in)
Weight	22.4 kg (49 lbs)

AC POWER

Operating range	100 - 250 V, 50/60 Hz
AC input	3-prong IEC male socket

MAXIMUM POWER AND CURRENT

100 V, 50 Hz	319 W, 3.8 A, PF 0.8
100 V, 60 Hz	317 W, 3.4 A, PF 0.9
120 V, 50 Hz	320 W, 2.9 A, PF 0.9
120 V, 60 Hz	314 W, 2.7 A, PF 1.0
208 V, 50 Hz	320 W, 1.9 A, PF 0.8
208 V, 60 Hz	319 W, 1.7 A, PF 0.9
230 V, 50 Hz	323 W, 1.6 A, PF 0.9
230 V, 60 Hz	326 W, 1.5 A, PF 1.0
250 V, 50 Hz	326 W, 1.5 A, PF 0.9
250 V, 60 Hz	325 W, 1.4 A, PF 1.0

Note: Measurements have a margin of error of +/- 10%

V = volts, Hz = hertz, W = watts, A = amps, PF = power factor

THERMAL

Maximum ambient temperature (T _a)	40° C (104° F)
Maximum surface temperature	120° C (248° F)

INSTALLATION

Orientation	any
Minimum distance to flammable materials	0.1 m (4 in)
Minimum distance to illuminated surfaces	0.3 m (12 in)

FUSES

Main fuse	6.3 A / 250 V, time-delay
Fuse F1	6.3 A / 250 V, time-delay
Fuse F2	2.0 A / 250 V, time-delay

LAMPS

Philips MSD 250/2	3000 hr, 8500K, 250 W
Osram HSD 250/78	3000 hr, 7800K, 250 W
GE CSD 250/2	2000 hr, 9000K, 250 W

GOBOS

Outside diameter	22.5 mm + 0/- 0.3 mm (0.886 in. +0/- 0.012 in)
Maximum image diameter	17 mm (0.669 in)
Maximum thickness	1.8 mm (0.071 in)
Glass type	high temperature Borofloat or better
Glass coating	dichroic or enhanced aluminum
Metal	aluminum (steel okay for short use)

CONTROL AND PROGRAMMING

Data input	locking 3-pin and 5-pin XLR male sockets
Data output	locking 3-pin and 5-pin XLR female sockets
Data pinout	pin 1 shield, pin 2 cold (-), pin 3 hot (+)
Receiver	Opto-isolated RS-485
Protocols	USITT DMX-512 (1990)
DMX Channels	Krypton - 14/17, Entour 15/18

DESIGN STANDARDS

Canadian safety	CSA C22.2 NO 166
EU EMC	EN 50 081-1, EN 50 082-1
EU safety	EN 60598-1, EN 60598-2-17
US safety	ANSI/UL 1573
CE approved	

PHOTOMETRICS

Total output	5000 lumens
One-tenth peak output	5000 lumens
Cutoff angle	20.1 degrees
One-tenth peak angle	19.2 degrees
Measurement conditions	230 V, 50 Hz; no effects applied
Measurement source	Philips MSD 250/2

INCLUDED ITEMS

Omega bracket, MAC 250/300 1/4-turn
XLR cable, 5 m, black, 3-pin
Mains cable, 3 m, IEC 3-pin
User manual

ACCESSORIES

G-clamp	P/N 91602003
Half-coupler clamp	P/N 91602005

ORDERING INFORMATION

MAC 250 Krypton (packed in cardboard box)	P/N 90225600
MAC 250 Krypton (in flightcase)	P/N 90225610

SPECIFICATIONS - MAC 250 ENTOUR

PHYSICAL

Base length	375 mm (14.8 in)
Base width	315 mm (12.4 in)
Yoke width	393 mm (15.5 in)
Height	538 mm (21.2 in)
Weight	22.4 kg (49 lbs)

AC POWER

Operating range	100 - 250 V, 50/60 Hz
AC input	3-prong IEC male socket

MAXIMUM POWER AND CURRENT

100 V, 50 Hz	319 W, 3.8 A, PF 0.8
100 V, 60 Hz	317 W, 3.4 A, PF 0.9
120 V, 50 Hz	320 W, 2.9 A, PF 0.9
120 V, 60 Hz	314 W, 2.7 A, PF 1.0
208 V, 50 Hz	320 W, 1.9 A, PF 0.8
208 V, 60 Hz	319 W, 1.7 A, PF 0.9
230 V, 50 Hz	323 W, 1.6 A, PF 0.9
230 V, 60 Hz	326 W, 1.5 A, PF 1.0
250 V, 50 Hz	326 W, 1.5 A, PF 0.9
250 V, 60 Hz	325 W, 1.4 A, PF 1.0

Note: Measurements have a margin of error of +/- 10%

V = volts, Hz = hertz, W = watts, A = amps, PF = power factor

THERMAL

Maximum ambient temperature (T _a)	40° C (104° F)
Maximum surface temperature	120° C (248° F)

INSTALLATION

Orientation	any
Minimum distance to flammable materials	0.1 m (4 in)
Minimum distance to illuminated surfaces	0.3 m (12 in)

FUSES

Main fuse	6.3 A / 250 V, time-delay
Fuse F1	6.3 A / 250 V, time-delay
Fuse F2	2.0 A / 250 V, time-delay

LAMPS

Philips MSD 250/2	3000 hr, 8500K, 250 W
Osram HSD 250/78	3000 hr, 7800K, 250 W
GE CSD 250/2	2000 hr, 9000K, 250 W

GOBOS

Outside diameter	22.5 mm + 0/- 0.3 mm (0.886 in. +0/- 0.012 in)
Maximum image diameter	17 mm (0.669 in)
Maximum thickness	1.8 mm (0.071 in)
Glass type	high temperature Borofloat or better
Glass coating	dichroic or enhanced aluminum
Metal	aluminum (steel okay for short use)

CONTROL AND PROGRAMMING

Data input	locking 3-pin and 5-pin XLR male sockets
Data output	locking 3-pin and 5-pin XLR female sockets
Data pinout	pin 1 shield, pin 2 cold (-), pin 3 hot (+)
Receiver	Opto-isolated RS-485
Protocols	USITT DMX-512 (1990)
DMX Channels	Krypton - 14/17, Entour 15/18

DESIGN STANDARDS

Canadian safety	CSA C22.2 NO 166
EU EMC	EN 50 081-1, EN 50 082-1
EU safety	EN 60598-1, EN 60598-2-17
US safety	ANSI/UL 1573
CE approved	

PHOTOMETRICS (ENTOUR)

Entour standard

Total output	5000 lumens
One-tenth peak output	5000 lumens
Cutoff angle	18.1 degrees
One-tenth peak angle	17.2 degrees

Entour narrow

Total output	4000 lumens
One-tenth peak output	4000 lumens
Cutoff angle	14.6 degrees
One-tenth peak angle	13.6 degrees
Measurement conditions	230 V, 50 Hz; no effects applied
Measurement source	Philips MSD 250/2

INCLUDED ITEMS

Omega bracket, MAC 250/300 1/4-turn
XLR cable, 5 m, black, 3-pin
Mains cable, 3 m, IEC 3-pin
14° lens
User manual

ACCESSORIES

G-clamp	P/N 91602003
Half-coupler clamp	P/N 91602005

ORDERING INFORMATION

MAC 250 Entour (packed in cardboard box)	P/N 90225710
MAC 250 Entour (in flightcase)	P/N 90225700